

INTERNATIONAL STANDARD

**Household and similar electrical appliances – Safety –
Part 2-90: Particular requirements for commercial microwave ovens**



THIS PUBLICATION IS COPYRIGHT PROTECTED

Copyright © 2015 IEC, Geneva, Switzerland

All rights reserved. Unless otherwise specified, no part of this publication may be reproduced or utilized in any form or by any means, electronic or mechanical, including photocopying and microfilm, without permission in writing from either IEC or IEC's member National Committee in the country of the requester. If you have any questions about IEC copyright or have an enquiry about obtaining additional rights to this publication, please contact the address below or your local IEC member National Committee for further information.

IEC Central Office
3, rue de Varembe
CH-1211 Geneva 20
Switzerland

Tel.: +41 22 919 02 11
Fax: +41 22 919 03 00
info@iec.ch
www.iec.ch

About the IEC

The International Electrotechnical Commission (IEC) is the leading global organization that prepares and publishes International Standards for all electrical, electronic and related technologies.

About IEC publications

The technical content of IEC publications is kept under constant review by the IEC. Please make sure that you have the latest edition, a corrigenda or an amendment might have been published.

IEC Catalogue - webstore.iec.ch/catalogue

The stand-alone application for consulting the entire bibliographical information on IEC International Standards, Technical Specifications, Technical Reports and other documents. Available for PC, Mac OS, Android Tablets and iPad.

IEC publications search - www.iec.ch/searchpub

The advanced search enables to find IEC publications by a variety of criteria (reference number, text, technical committee,...). It also gives information on projects, replaced and withdrawn publications.

IEC Just Published - webstore.iec.ch/justpublished

Stay up to date on all new IEC publications. Just Published details all new publications released. Available online and also once a month by email.

Electropedia - www.electropedia.org

The world's leading online dictionary of electronic and electrical terms containing more than 30 000 terms and definitions in English and French, with equivalent terms in 15 additional languages. Also known as the International Electrotechnical Vocabulary (IEV) online.

IEC Glossary - std.iec.ch/glossary

More than 60 000 electrotechnical terminology entries in English and French extracted from the Terms and Definitions clause of IEC publications issued since 2002. Some entries have been collected from earlier publications of IEC TC 37, 77, 86 and CISPR.

IEC Customer Service Centre - webstore.iec.ch/csc

If you wish to give us your feedback on this publication or need further assistance, please contact the Customer Service Centre: csc@iec.ch.



IEC 60335-2-90

Edition 4.0 2015-08

INTERNATIONAL STANDARD

**Household and similar electrical appliances – Safety –
Part 2-90: Particular requirements for commercial microwave ovens**

INTERNATIONAL
ELECTROTECHNICAL
COMMISSION

ICS 97.040.20

ISBN 978-2-8322-2857-9

Warning! Make sure that you obtained this publication from an authorized distributor.

CONTENTS

FOREWORD.....	4
INTRODUCTION.....	7
1 Scope.....	8
2 Normative references.....	9
3 Definitions	9
4 General requirement.....	12
5 General conditions for the tests.....	12
6 Classification	13
7 Marking and instructions	13
8 Protection against access to live parts	15
9 Starting of motor-operated appliances.....	15
10 Power input and current.....	15
11 Heating.....	15
12 Void.....	16
13 Leakage current and electric strength at operating temperature.....	16
14 Transient overvoltages.....	16
15 Moisture resistance.....	16
16 Leakage current and electric strength.....	16
17 Overload protection of transformers and associated circuits	17
18 Endurance	17
19 Abnormal operation.....	18
20 Stability and mechanical hazards	19
21 Mechanical strength.....	20
22 Construction	22
23 Internal wiring	26
24 Components	26
25 Supply connection and external flexible cords	27
26 Terminals for external conductors	28
27 Provision for earthing.....	28
28 Screws and connections	28
29 Clearances, creepage distances and solid insulation	28
30 Resistance to heat and fire	28
31 Resistance to rusting	28
32 Radiation, toxicity and similar hazards.....	28
Annex A (informative) Routine tests.....	30
Annex AA (normative) Combination microwave ovens.....	32
Annex BB (normative) Requirements for commercial microwave ovens without a cavity door and with conveyor-type means.....	34
Annex CC (informative) Overview of the requirements for covers, means of access and similar.....	47
Annex DD (informative) Rationales for the microwave barrier and associated leakage tests	48

Annex EE (normative) Microwave ovens intended to be used on board ships 54

Bibliography 57

Figure 101 – Test rod for interlock concealment 29

Figure BB.1 – Splash apparatus 44

Figure BB.2 – Arrangement for measurement of microwave leakage from access openings 45

Figure BB.3 – Examples of definitions of Clause 3 and Clause BB.3 46

Table 101 – Number of potatoes 19

Table BB.101 – Specifications for microwave barriers 41

INTERNATIONAL ELECTROTECHNICAL COMMISSION

HOUSEHOLD AND SIMILAR ELECTRICAL APPLIANCES – SAFETY –

Part 2-90: Particular requirements for commercial microwave ovens

FOREWORD

- 1) The International Electrotechnical Commission (IEC) is a worldwide organization for standardization comprising all national electrotechnical committees (IEC National Committees). The object of IEC is to promote international co-operation on all questions concerning standardization in the electrical and electronic fields. To this end and in addition to other activities, IEC publishes International Standards, Technical Specifications, Technical Reports, Publicly Available Specifications (PAS) and Guides (hereafter referred to as "IEC Publication(s)"). Their preparation is entrusted to technical committees; any IEC National Committee interested in the subject dealt with may participate in this preparatory work. International, governmental and non-governmental organizations liaising with the IEC also participate in this preparation. IEC collaborates closely with the International Organization for Standardization (ISO) in accordance with conditions determined by agreement between the two organizations.
- 2) The formal decisions or agreements of IEC on technical matters express, as nearly as possible, an international consensus of opinion on the relevant subjects since each technical committee has representation from all interested IEC National Committees.
- 3) IEC Publications have the form of recommendations for international use and are accepted by IEC National Committees in that sense. While all reasonable efforts are made to ensure that the technical content of IEC Publications is accurate, IEC cannot be held responsible for the way in which they are used or for any misinterpretation by any end user.
- 4) In order to promote international uniformity, IEC National Committees undertake to apply IEC Publications transparently to the maximum extent possible in their national and regional publications. Any divergence between any IEC Publication and the corresponding national or regional publication shall be clearly indicated in the latter.
- 5) IEC itself does not provide any attestation of conformity. Independent certification bodies provide conformity assessment services and, in some areas, access to IEC marks of conformity. IEC is not responsible for any services carried out by independent certification bodies.
- 6) All users should ensure that they have the latest edition of this publication.
- 7) No liability shall attach to IEC or its directors, employees, servants or agents including individual experts and members of its technical committees and IEC National Committees for any personal injury, property damage or other damage of any nature whatsoever, whether direct or indirect, or for costs (including legal fees) and expenses arising out of the publication, use of, or reliance upon, this IEC Publication or any other IEC Publications.
- 8) Attention is drawn to the Normative references cited in this publication. Use of the referenced publications is indispensable for the correct application of this publication.
- 9) Attention is drawn to the possibility that some of the elements of this IEC Publication may be the subject of patent rights. IEC shall not be held responsible for identifying any or all such patent rights.

This part of International Standard IEC 60335 has been prepared by subcommittee 61B: Safety of microwave appliances for household and commercial use, of IEC technical committee 61: Safety of household and similar electrical appliances.

This fourth edition cancels and replaces the third edition published in 2006 including its Amendment 1 (2010) and Amendment 2 (2014). It constitutes a technical revision.

The principal changes with respect to the previous edition are as follows (minor and editorial changes are not listed):

- a statement in 7.12 is required for appliances intended to be used on commercial road vehicles;
- a statement in 7.12 is required concerning cleaning of the appliance with a water jet;
- the replacement of 22.103, 22.104 and 22.105 allows interlock systems with at least one concealed door interlock as well as alternative interlock systems without concealed door interlock;

- requirements are added for appliances for installation in commercial road vehicles;
- an annex is added dealing with routine tests.

The text of this standard is based on the following documents:

FDIS	Report on voting
61B/529/FDIS	61B/536/RVD

Full information on the voting for the approval of this standard can be found in the report on voting indicated in the above table.

This publication has been drafted in accordance with the ISO/IEC Directives, Part 2.

This Part 2 is to be used in conjunction with the latest edition of IEC 60335-1 and its amendments. It was established on the basis of the fourth edition (2001) of that standard.

NOTE 1 When "Part 1" is mentioned in this standard, it refers to IEC 60335-1.

This Part 2 supplements or modifies the corresponding clauses in IEC 60335-1, so as to convert that publication into the IEC standard: Safety requirements for commercial microwave ovens.

When a particular subclause of Part 1 is not mentioned in part 2, that subclause applies as far as is reasonable. When this standard states "addition", "modification" or "replacement", the relevant text in Part 1 is to be adapted accordingly.

NOTE 2 The following numbering system is used:

- subclauses, tables and figures that are numbered starting from 101 are additional to those in Part 1;
- unless notes are in a new subclause or involve notes in Part 1, they are numbered starting from 101, including those in a replaced clause or subclause;
- additional annexes are lettered AA, BB, etc.

NOTE 3 The following print types are used:

- requirements: in roman type;
- *test specifications: in italic type;*
- notes: in small roman type.

Words in **bold** type in the text are defined in Clause 3. When a definition concerns an adjective, the adjective and the associated noun are also in bold.

The following differences exist in the countries indicated below.

- 5.3: Microwave leakage is not to exceed 10 W/m² during the initial test (Japan, USA and Canada).
- 6.1: Microwave ovens may be class OI if the rated voltage does not exceed more than 150 V (Japan).
- 7.12: Some warnings have to be marked on the appliance and be visible to the user (Canada).
- Clause 18: The test is carried out on two appliances (USA).
- 19.11.2: The input voltage variation is not applied (USA).
- 19.13: Microwave leakage is only measured at the end of each test (USA).
- 21.102: The applied force is 222 N (USA).
- 21.105: Microwave leakage is not to exceed 50 W/m² (Japan and USA).
- 22.111: Microwave leakage is only measured at the end of the test (USA).

- 22.112: Microwave leakage is not to exceed 50 W/m² (Japan and USA).
- 22.116: All access to the cavity has to be prevented (USA).
- 27.2: A terminal for an external equipotential conductor is not required (Japan).

A list of all parts of the IEC 60335 series, under the general title: *Household and similar electrical appliances – Safety*, can be found on the IEC website.

The committee has decided that the contents of this publication will remain unchanged until the stability date indicated on the IEC website under "<http://webstore.iec.ch>" in the data related to the specific publication. At this date, the publication will be

- reconfirmed,
- withdrawn,
- replaced by a revised edition, or
- amended.

A bilingual version of this publication may be issued at a later date.

NOTE The attention of National Committees is drawn to the fact that equipment manufacturers and testing organizations can need a transitional period following publication of a new, amended or revised IEC publication in which to make products in accordance with the new requirements and to equip themselves for conducting new or revised tests.

It is the recommendation of the committee that the content of this publication be adopted for implementation nationally not earlier than 12 months or later than 36 months from the date of publication.

INTRODUCTION

It has been assumed in the drafting of this international standard that the execution of its provisions is entrusted to appropriately qualified and experienced persons.

This standard recognizes the internationally accepted level of protection against hazards such as electrical, mechanical, thermal, fire and radiation of appliances when operated as in normal use taking into account the manufacturer's instructions. It also covers abnormal situations that can be expected in practice and takes into account the way in which electromagnetic phenomena can affect the safe operation of appliances.

This standard takes into account the requirements of IEC 60364 as far as possible so that there is compatibility with the wiring rules when the appliance is connected to the supply mains. However, national wiring rules may differ.

If an appliance within the scope of this standard also incorporates functions that are covered by another part 2 of IEC 60335, the relevant part 2 is applied to each function separately, as far as is reasonable. If applicable, the influence of one function on the other is taken into account.

When a part 2 standard does not include additional requirements to cover hazards dealt with in Part 1, Part 1 applies.

NOTE 1 This means that the technical committees responsible for the part 2 standards have determined that it is not necessary to specify particular requirements for the appliance in question over and above the general requirements.

This standard is a product family standard dealing with the safety of appliances and takes precedence over horizontal and generic standards covering the same subject.

NOTE 2 Horizontal and generic standards covering a hazard are not applicable since they have been taken into consideration when developing the general and particular requirements for the IEC 60335 series of standards. For example, in the case of temperature requirements for surfaces on many appliances, generic standards, such as ISO 13732-1 for hot surfaces, are not applicable in addition to Part 1 or part 2 standards.

An appliance that complies with the text of this standard will not necessarily be considered to comply with the safety principles of the standard if, when examined and tested, it is found to have other features which impair the level of safety covered by these requirements.

An appliance employing materials or having forms of construction differing from those detailed in the requirements of this standard may be examined and tested according to the intent of the requirements and, if found to be substantially equivalent, may be considered to comply with the standard.

HOUSEHOLD AND SIMILAR ELECTRICAL APPLIANCES – SAFETY –

Part 2-90: Particular requirements for commercial microwave ovens

1 Scope

This clause of Part 1 is replaced by the following.

This International Standard deals with:

- the safety of **microwave ovens** with a cavity door intended for commercial use, their **rated voltage** being not more than 250 V for single-phase appliances connected between one phase and neutral and 480 V for other appliances;
- the safety of **combination microwave ovens** with a cavity door, the requirements for which are contained in Annex AA;
- the safety of **microwave ovens** without a cavity door and with **transportation means** that are intended for commercial use only, for the heating of food and beverages, the requirements for which are contained in Annex BB.

Microwave ovens covered by Annex BB have **transportation means** for moving the **load** through the **microwave oven**. Requirements for tunnel microwave ovens and several types of microwave vending machines are covered.

This standard also deals with **microwave ovens** intended to be used on board ships, for which Annex EE is applicable.

NOTE 101 In Annex BB, a microwave oven without a cavity door and with **transportation means** is described as a **microwave oven**. All clauses of this standard apply to these appliances unless otherwise specified in Annex BB.

This international standard also takes into account **ordinary persons** having access to the **removing area** of the vending machine.

NOTE 102 The appliance may be built into a vending machine, in which case IEC 60335-2-75 may also be applicable.

NOTE 103 Appliances that use non-electrical energy are within the scope of this standard.

In general, this standard does not take into account

- the use of appliances by young children or infirm persons without supervision;
- playing with the appliance by young children.

This international standard does not take into account the use of a **microwave oven** without a cavity door and with **transportation means** by **ordinary persons** except in the vicinity of **entrance and exit ports**.

NOTE 104 The rationales for particular microwave exposure conditions and measures related to microwave energy being confined by an open structure are in Annex BB.

NOTE 105 Attention is drawn to the fact that

- for appliances intended to be used in vehicles or on board ships or aircraft, additional requirements may be necessary;
- for appliances intended to be used in tropical countries, special requirements may be necessary;
- in many countries, the national health authorities, the national authorities responsible for the protection of labour and similar authorities specify additional requirements;

- in many countries, national authorities specify additional requirements to BB.22.119.1.

NOTE 106 This standard does not apply to

- household **microwave ovens** including **combination microwave ovens** (IEC 60335-2-25);
- industrial microwave heating equipment (IEC 60519-6);
- appliances for medical purposes (IEC 60601);
- appliances intended to be used in locations where special conditions prevail, such as the presence of a corrosive or explosive atmosphere (dust, vapour or gas).

2 Normative references

This clause of Part 1 is applicable except as follows.

Addition:

IEC 60068-2-6, *Environmental testing – Part 2-6: Tests – Test Fc: Vibration (sinusoidal)*

IEC 60068-2-27, *Environmental testing – Part 2-27: Tests – Test Ea and guidance: Shock*

IEC 60068-2-52, *Environmental testing – Part 2-52: Tests – Test Kb: Salt mist, cyclic (sodium chloride solution)*

IEC 60436:2004, *Electric dishwashers for household use – Methods for measuring the performance*

IEC 60436:2004/AMD 1:2009

IEC 60436:2004/AMD 2:2012

3 Definitions

This clause of Part 1 is applicable except as follows.

3.1.7 *Addition:*

Note 101 to entry: The **rated frequency** is the input frequency.

3.1.9 *Replacement:*

normal operation

operation of the appliance under the following conditions:

The appliance is operated with 1 000 g ± 50 g of potable water at an initial temperature of 20 °C ± 2 °C in a cylindrical borosilicate glass vessel having a maximum thickness of 3 mm and an outside diameter of approximately 190 mm. The vessel is placed on the centre of the **shelf**. If the **rated microwave power output** exceeds 2 200 W, two such vessels are used and placed contiguously in the **cavity**.

3.101

microwave oven

appliance using electromagnetic energy in one or several of the ISM frequency bands¹ between 300 MHz and 30 GHz, for heating food and beverages in a **cavity**

¹ ISM frequency bands are the electromagnetic frequencies established by the ITU and reproduced in CISPR 11.

3.102

rated microwave power output

microwave power output assigned to the appliance by the manufacturer

3.103

cavity

space enclosed by the inner walls and the door in which the **load** is placed

3.104

shelf

horizontal support in the **cavity** on which the **load** is placed

3.105

door interlock

device or system that prevents the operation of the magnetron unless the oven door is closed

3.106

monitored door interlock

door interlock system that incorporates a supervision device

3.107

temperature-sensing probe

device that is inserted into the food to measure its temperature and is a part of an oven control

3.108

instructed person

person who is sufficiently instructed and monitored to know how to avoid any danger caused by the operation of **microwave ovens**

3.109

skilled person

person with suitable professional education, knowledge and experience to discern and to avoid any danger caused by the operation of **microwave ovens**

3.110

ordinary person

person who is neither a **skilled person** nor an **instructed person**

3.111

transportation means

means to transport the **load** through the **microwave oven**

Note 1 to entry: An example of a **transportation means** is a belt, an arm or an inclined plane.

3.112

load

food and beverages that can be heated up in a **microwave oven**

3.113

microwave enclosure

structure that is intended to confine microwave energy to a defined region

Note 2 to entry: Barriers mounted outside the **microwave enclosure** are not considered a part of the **microwave enclosure**.

Note 3 to entry: A **microwave enclosure** may consist of a **cavity**, quarter wave chokes (acting by impedance transformation), mode chokes (acting by field pattern mismatching) and microwave energy absorbers.

3.114**microwave barrier**

physical barrier, which is microwave transparent, limiting access to the **microwave enclosure**, mounted outside the **microwave enclosure** and can only be removed with the aid of tools

Note 1 to entry: A **microwave barrier** may be mounted between the **microwave enclosure** and the external cover of the appliance.

Note 2 to entry: Devices such as an array of metal chains or hinged metal plates at **entrance and exit ports** intended to reduce microwave leakage are not considered **microwave barriers**.

Note 3 to entry: Construction requirements are given in BB.22.119.

3.115**entrance and exit ports**

openings in the **microwave enclosure** through which **loads** move

3.116**loading area**

area on which the **load** is placed

3.117**means of monitored microwave interlock**

means of microwave interlock that incorporates a supervision device

3.118**protective blocking structure**

movable mechanical structure located in the **removing area** limiting access to the **microwave enclosure**

3.119**removing area**

area from which the **load** is removed

3.120**viewing opening**

opening in the **cavity** through which the warm up process can be visually monitored

3.121**fixed means of connection**

all parts of the **microwave enclosure** that are permanently open with the exception of **entrance and exit ports** and **viewing openings**

Note 1 to entry: **Fixed means of connection** may be used for venting and water flushing.

3.122**detachable means of access**

all parts of the **microwave enclosure** that can be opened or removed without the aid of tools to get access to the inside for maintenance, with the exception of **entrance and exit ports** and **viewing openings**

Note 1 to entry: Examples of **detachable means of access** are tunnels that are opened by drop down or sliding action and cavity lamp covers.

3.123**means of microwave interlock**

mechanical or electrical safety devices or systems that operate when certain conditions are not fulfilled (e.g. an interlock system that prevents the operation of the microwave generator when a means of access is open)

3.124**maintenance cover**

structural feature of any part of the equipment that can be opened or removed by the use of a tool to provide access for routine maintenance, service, replacement of expendable parts, etc. in microwave containing areas

3.125**cleaning cover**

part of the **microwave enclosure** that can be opened or removed, only with the aid of a tool, for frequent cleaning purposes, during operation

3.126**reference surface**

surface in the vicinity of entrance and exits ports defined depending on the reading of microwave leakage of Clause BB.32

Note 1 to entry: If the leakage reading is less or equal to 50 W/m^2 , the **reference surface** is the surface of the geometric opening of the **microwave enclosure** without **microwave barrier**.

Note 2 to entry: If the leakage reading exceeds 50 W/m^2 , the **reference surface** is an artificial surface located 50 mm away from the locations where the sensor of the instrument measures leakage readings of 50 W/m^2 straight inwards towards the appliance.

Note 3 to entry: For further explanation, refer to Clause BB.32.

3.127**combination microwave oven**

microwave oven in which heat is also provided in the **cavity** by simultaneous or consecutive operation of resistive heating elements

Note 1 to entry: The resistive heating elements are used to provide radiant heat, convection heat or steam.

3.128**hot functional surface**

surface that is intentionally heated by an internal heat source and that has to be hot to carry out the intended function of the appliance

4 General requirement

This clause of Part 1 is applicable.

5 General conditions for the tests

This clause of Part 1 is applicable except as follows.

5.2 Addition:

NOTE 101 An additional sample may be required for the test of 19.104. Six samples of the interlocks are required for the test of 24.1.4.

5.3 Modification:

Instead of carrying out the tests in the order of clauses, the following sequence of clauses and subclauses applies: 32, 22.113, 22.108, 22.116, 7 to 17, 20, 21 (except 21.101 to 21.105), 18, 19 (except 19.104), 22 (except 22.108, 22.113 and 22.116), 23 to 31, 21.101 to 21.105 and 19.104.

5.101 Microwave ovens are tested as motor-operated appliances.

5.102 Class III temperature-sensing probes are only subjected to the tests of 22.112.

6 Classification

This clause of Part 1 is applicable except as follows.

6.1 Modification:

Microwave ovens shall be **class I**.

7 Marking and instructions

This clause of Part 1 is applicable except as follows.

7.1 Addition:

Appliances shall be marked with the nominal frequency in megahertz of the ISM band in which they operate.

If the removal of any cover results in microwave leakage exceeding the value specified in Clause 32, the cover shall be marked with the substance of the following:

WARNING: Microwave energy – Do not remove this cover

If an appliance incorporates a socket-outlet protected by means of fuses other than D-type fuses, it shall be marked with the rated current of the relevant fuse. When a miniature fuse-link is provided, this marking shall indicate that the fuse-link is to have a high breaking capacity.

If appliances have external enclosures, other than working surfaces, that cannot meet the limit in Table 3 specified for external enclosures of **motor-operated appliances**, they shall be marked with symbol IEC 60417-5041(2002-10) or with the substance of the following:

CAUTION: Hot surface.

7.6 Addition:



[symbol IEC 60417-5021 (2002-10)] equipotentiality



[symbol IEC 60417-5041 (2002-10)] caution, hot surface

7.12 Addition:

The instructions shall include the substance of the following:

- WARNING: If the door or door seals are damaged, the oven must not be operated until it has been repaired by a competent person;
- WARNING: It is hazardous for anyone other than a competent person to carry out any service or repair operation that involves the removal of any cover which gives protection against exposure to microwave energy;

- WARNING: Liquids or other foods must not be heated in sealed containers since they are liable to explode;
- WARNING: Microwave heating of beverages can result in delayed eruptive boiling, therefore care must be taken when handling the container;
- WARNING: The contents of feeding bottles and baby food jars must be stirred or shaken and the temperature checked before consumption, in order to avoid burns;
- the minimum height of free space necessary above the top surface of the oven;
- only use utensils that are suitable for use in **microwave ovens**;
- when heating food in plastic or paper containers, keep an eye on the oven due to the possibility of ignition;
- if smoke is observed, switch off or unplug the appliance and keep the door closed in order to stifle any flames;
- eggs in their shell and whole hard-boiled eggs should not be heated in **microwave ovens** since they may explode even after microwave heating has ended;
- details for cleaning door seals, cavities and adjacent parts;
- the oven should be cleaned regularly and any food deposits removed;
- failure to maintain the oven in a clean condition could lead to deterioration of the surface that could adversely affect the life of the appliance and possibly result in a hazardous situation;
- only use the temperature probe recommended for this oven (for appliances having a facility to use a **temperature-sensing probe**);
- the appliance should not be cleaned with a water jet (for appliances intended to stand on the floor and which are not at least IPX5);
- statement on usage on commercial road vehicles (for appliances intended to be used on commercial road vehicles);
- the appliance must not be cleaned with a steam cleaner (for appliances which are not at least IPX5).

NOTE 101 If the oven is incorporated in a vending machine, these warnings and instructions may not be relevant and therefore not required.

7.14 Addition:

The warning specified in 7.1 shall be in lettering at least 3 mm high.

The warning specified in 7.101 shall be in lettering at least 5 mm high.

The height of the triangle used with symbol IEC 60417-5041 (2002-10) shall be at least 12 mm.

7.15 Addition:

The marking specified for hot surfaces shall be visible when the appliance is operated as in normal use, including when actuating any switch, adjusting any control or opening a lid or door. It shall not be placed on a **hot functional surface**.

7.101 A label shall be provided, together with instructions for fixing it in a conspicuous place close to the appliance. The label shall state the substance of the following.

- WARNING: Liquids or other foods must not be heated in sealed containers since they are liable to explode;
- WARNING: Microwave heating of beverages can result in delayed eruptive boiling, therefore care must be taken when handling the container;

- **WARNING:** The contents of feeding bottles and baby food jars must be stirred or shaken and the temperature checked before consumption, in order to avoid burns.

Compliance is checked by inspection.

8 Protection against access to live parts

This clause of Part 1 is applicable.

9 Starting of motor-operated appliances

This clause of Part 1 is not applicable.

10 Power input and current

This clause of Part 1 is applicable.

11 Heating

This clause of Part 1 is applicable except as follows.

11.2 Addition:

*Appliances, other than **built-in appliances**, are positioned as specified for **heating appliances**.*

A ceiling is placed over the appliance at the minimum height stated in the instructions. The ceiling has a depth of 300 mm from the back wall of the test corner and a length at least 150 mm in excess of the width of the appliance.

Appliances intended to be fixed to the floor, and appliances with a mass greater than 40 kg and not provided with rollers, castors or similar means, are installed in accordance with the installation instructions. If no instructions are supplied, these appliances are placed on the floor as near as possible to the walls of the test corner.

11.7 Replacement:

Appliances are operated in cycles, each cycle consisting of a heating period of 4 min followed by a rest period of 1 min until steady conditions are established. Boiling water is added to the water load when half of the water load has evaporated.

11.8 Addition:

The temperature rises of external surfaces are only measured on the surfaces that are not placed against the wall and the floor of the test corner.

*There are no temperature limits for air-outlet grilles and for surfaces up to a distance of 25 mm from them. When the required values for external enclosures of **motor-operated appliances** are not met, the maximum temperature rise shall not be higher than two times the values indicated.*

12 Void

13 Leakage current and electric strength at operating temperature

This clause of Part 1 is applicable.

14 Transient overvoltages

This clause of Part 1 is applicable.

15 Moisture resistance

This clause of Part 1 is applicable except as follows.

15.2 Addition:

*A quantity of 0,5 l of water containing approximately 1 % NaCl is poured steadily over the **shelf** over a period of 1 min. If the **shelf** can collect spilled liquid, it is filled with the saline solution and a further 0,5 l is then added over a period of 1 min.*

15.101 Temperature-sensing probes shall be constructed so that their insulation is not affected by water.

Compliance is checked by the following test.

The probe is completely immersed in water containing approximately 1 % NaCl and having a temperature of 20 °C ± 5 °C. The water is heated to the boiling point in approximately 15 min. The probe is then removed from the boiling water and immersed in water having a temperature of 20 °C ± 5 °C for 30 min.

This procedure is carried out five times, after which the probe is removed from the water. All traces of liquid are then removed from the surface.

The probe shall then withstand the leakage current test of 16.2.

NOTE **Detachable temperature-sensing probes** are not connected to the appliance for this test. **Non-detachable temperature-sensing probes** are tested in the oven, the probe being immersed as much as possible.

16 Leakage current and electric strength

This clause of Part 1 is applicable except as follows.

16.101 The windings of the power transformer that supplies the magnetron shall have adequate insulation.

Compliance is checked by the test of 16.101.1 for switch-mode power supplies and by the test of 16.101.2 for other power transformers.

16.101.1 *The insulation between the primary and secondary windings of switch-mode power supply transformers is subjected for 1 min to a voltage of substantially sinusoidal waveform and having a frequency of 50 Hz or 60 Hz. The value of the voltage is 1,414 times the peak value of the secondary **working voltage** plus 750 V, with a minimum of 1 250 V.*

There shall be no breakdown between windings or between adjacent turns of the same winding.

16.101.2 *Twice the **working voltage** is induced in the secondary winding of the transformer by applying a sinusoidal voltage having a frequency higher than **rated frequency** to the primary terminals.*

The duration of the test is

- 60 s, for frequencies up to twice the **rated frequency**, or
- $120 \times \frac{\text{rated frequency}}{\text{test frequency}}$ s, with a minimum of 15 s, for higher frequencies.

NOTE The frequency of the test voltage is higher than the **rated frequency** to avoid excessive excitation current.

A maximum of one-third of the test voltage is applied and is then rapidly increased without creating transients. At the end of the test, the voltage is decreased in a similar manner to approximately one-third of its full value before switching off.

There shall be no breakdown between windings or between adjacent turns of the same winding.

17 Overload protection of transformers and associated circuits

This clause of Part 1 is applicable except as follows.

Addition:

The tests are not carried out on the power transformer that supplies the magnetron and its associated circuits, these are checked during the tests of Clause 19.

18 Endurance

This clause of Part 1 is replaced by the following.

The door system, including hinges, microwave seals and other associated parts, shall be constructed to withstand wear that may be expected in normal use.

Compliance is checked by the following test.

*The door system is subjected to 100 000 cycles of operation with the appliance supplied at **rated voltage** and containing an appropriate microwave-absorbing load. It is then subjected to 100 000 cycles of operation without microwave generation.*

The door is opened and closed as in normal use. It is opened from the closed position to a position approximately 10° before fully open. The rate of operation is six cycles per minute. With the agreement of the manufacturer, the rate of operation without microwave generation can be increased to 12 cycles per minute.

After the test, the microwave leakage shall not exceed the limit specified in Clause 32 and the door system shall still function.

NOTE 101 Controls may be rendered inoperative in order to carry out the test.

NOTE 102 Components, the deterioration of which does not impair compliance with this standard, may be replaced in order to complete the test.

NOTE 103 Bricks or additional water of maximum 1 000 g may be added if necessary to avoid stopping of the test due to overheating.

19 Abnormal operation

This clause of Part 1 is applicable except as follows.

19.1 Modification:

*Instead of subjecting the appliance to the tests of 19.2 to 19.10, compliance is checked by the tests of 19.101 to 19.104, the appliance being supplied at **rated voltage**.*

19.11.2 Addition:

*The cathode to anode circuit of the magnetron is open-circuited and short-circuited in turn. If one of these fault conditions results in an input current that increases with decreasing voltage, the test is carried out with the appliance supplied at 0,94 times **rated voltage**. However, if the input current increases more than proportionally with voltage, the appliance is supplied at 1,06 times **rated voltage**.*

The filament of the magnetron is not short-circuited.

19.13 Addition:

The temperature of windings shall not exceed the values shown in Table 8. Only appliances that allow a preselected start time and those operating with a keep warm function are considered to be appliances operated until steady conditions are established.

During the tests, the microwave leakage shall not exceed 100 W/m² measured in accordance with Clause 32 but with the load as specified for each subclause. The appliance shall comply with Clause 32 if it can be operated after the tests.

19.101 *Appliances are operated with controls set at the most unfavourable position and without a load in the **cavity**.*

The period of operation is the maximum time allowed by the timer or until steady conditions are established, whichever is shorter.

19.102 *Appliances are operated under **normal operation** with the timer or other controls that operate in normal use short-circuited.*

NOTE If the appliance is provided with more than one control, these are short-circuited in turn.

19.103 *Appliances are operated under **normal operation** and with any single-fault condition simulated that is likely to occur. The controls are adjusted to their most unfavourable setting and the appliance is operated for the maximum time allowed by the timer or 90 min, whichever is shorter.*

NOTE Examples of fault conditions are

- blocking of air openings in the same plane;
- locking the rotor of motors if the locked rotor torque is smaller than the full load torque;
- locking moving parts liable to be jammed.

19.104 *The appliance is operated with the controls adjusted to their most unfavourable setting and with potatoes placed on the **shelf** in the position where they are most likely to ignite and propagate flames to other combustible material.*

Each potato has an approximately ellipsoidal shape and a mass between 125 g and 150 g. The length of the shorter principal axis is at least 40 mm. The length of the longer principal axis is not more than 140 mm and may be symmetrically reduced in order to obtain the specified mass. A steel wire, having a diameter of $1,5 \text{ mm} \pm 0,5 \text{ mm}$ and approximately the same length as the longer axis of the potato, is inserted along this axis of at least one of the potatoes. The number of potatoes to be used is stated in Table 101.

If the potatoes do not ignite, the test is repeated with the load reduced by one potato. If a single potato does not ignite, it is ignited artificially.

Table 101 – Number of potatoes

Rated microwave power output <i>W</i>	Volume of the cavity <i>l</i>	Number of potatoes
<600	≥ 14 and ≤ 28	2
≥ 600 and $\leq 1\ 000$	≥ 28 and ≤ 42	4
$\geq 1\ 000$ and $\leq 2\ 000$	≥ 42 and ≤ 56	6
$\geq 2\ 000$	≥ 56	$6 + N^a$
<i>NOTE The rated microwave power output or the volume of the cavity applies, whichever results in the higher number of potatoes</i>		
^a <i>N is 2 for each 500 W increase in power output or for each 14 l increase in volume.</i>		

*The test is terminated 15 min after the microwave generation has ceased or a fire in the **cavity** has extinguished.*

*During the test, any fire in the **cavity** shall be contained within the appliance.*

NOTE 1 Subclause 19.13 does not apply during the test.

*After the test, if the appliance is still operable, any damaged **detachable shelf** is replaced and 19.13 applies. If the appliance does not comply, the test is repeated on a new appliance.*

NOTE 2 Non-compliance may have resulted from the cumulative effects of previous tests.

20 Stability and mechanical hazards

This clause of part 1 is applicable except as follows.

20.101 Appliances having doors with a horizontal hinge at their lower edge and on which a load is likely to be placed shall have adequate stability.

Compliance is checked by the following test.

The appliance is placed on a horizontal surface with the door open and a mass is gently placed on the geometric centre of the door.

For appliances normally used on the floor, the mass is

- 23 kg for cavity doors, or the mass that can be placed in the oven in accordance with the instructions, if this is higher;
- 7 kg for other doors.

For appliances normally used on a table, the mass is

- 7 kg for **stationary appliances**;
- 3,5 kg for other appliances.

The appliance shall not tilt.

NOTE 1 A sandbag can be used for the load.

NOTE 2 For appliances having more than one door, the tests are made on each door separately.

21 Mechanical strength

This clause of Part 1 is applicable except as follows.

21.1 Addition:

Compliance is also checked by the tests of 21.101 to 21.105.

21.101 Hinged doors are positioned approximately 30° before the fully open position. Sliding doors are positioned so that they are approximately two-thirds open. A force of 35 N is applied to the inside surface of a hinged door at a point 25 mm from its free edge or to the handle of a sliding door.

The force is applied by means of a spring balance having a spring constant of 1,05 N/mm. It is initially applied with an opposing force applied to the other side of the door or handle. The opposing force is then removed to allow the door to complete its travel to the fully open position.

The test is carried out 25 times.

The test is repeated on doors of **stationary appliances** and **built-in appliances** except that

- the door is initially placed midway between the fully open and closed positions;
- the applied force is 1,5 times the force required to open the door or 65 N, whichever is greater. However if the force cannot be measured or if the door is opened indirectly, the 65 N force is applied.

The test is carried out 25 times.

Doors are placed midway between the fully open and closed positions. A closing force of 90 N is applied to the outside surface of a hinged door at a point 25 mm from the free edge or to the handle of a sliding door, initially with the opposing force as described above.

This test is carried out 50 times.

The appliance shall then comply with Clause 32.

21.102 Side-hinged doors are placed in the fully open position. A downward force of 140 N or the maximum force that can be applied in any door position without tilting the appliance, whichever is smaller, is then applied to the free edge of the door and the door is closed. The door is fully opened again with the force still applied.

This test is carried out 10 times.

Bottom-hinged doors are opened. A force of 140 N or the maximum force that can be applied without tilting the appliance, whichever is smaller, is applied to the inside surface of the door at the most unfavourable position 25 mm from the free edge.

The force is applied for 15 min.

The appliance shall then comply with Clause 32.

21.103 *A cube of wood having a side dimension of 20 mm is attached to an inside corner furthest from the door hinge. An attempt is made to close the door with a force of 90 N applied at the other corner farthest from the hinge in the direction perpendicular to the surface of the door.*

The force is maintained for 5 s.

The cube is then removed. The door is slowly closed until microwave generation becomes possible. The door and its opening means are then manipulated in order to determine the position resulting in the highest microwave leakage.

The appliance shall then comply with Clause 32.

The test is repeated with the wooden cube attached to the other corner farthest from the hinge.

NOTE The test is not applicable to sliding doors.

21.104 *The door is closed and its outside surface subjected to three impacts, each having an energy of 3 J. These impacts are applied to the central part of the door and may be at the same point.*

The impact is applied by means of a steel ball having a diameter of 50 mm and a mass of approximately 0,5 kg. The ball is suspended by a suitable cord that is held in the plane of the door. The ball is allowed to fall as a pendulum through the distance required to strike the surface with the specified impact energy.

The door is then opened and its mating surface on the oven is subjected to three similar impacts.

The inside surface of a hinged door is subjected to three impacts as before, the test being made with the door in the fully open position. The impacts are applied to the central part of the door and may be at the same point. However, if a bottom-hinged door is horizontal when in the fully open position, the impacts are applied by allowing the steel ball to fall freely through a distance such that the specified impact energy is obtained.

A bottom-hinged door is further tested by subjecting its seal to three similar impacts. The impacts are made at three different locations.

The appliance shall then comply with Clause 32.

21.105 *A bottom-hinged door is opened and a hardwood dowel having a diameter of 10 mm and a length of 300 mm is placed along the bottom hinge. The dowel is positioned such that one end is flush with an outside edge of the door. A closing force of 140 N is applied to the centre of the handle in a direction perpendicular to the surface of the door. The force is maintained for 5 s.*

The test is repeated with the end of the dowel flush with the other outside edge and then with the dowel positioned centrally within the door hinge.

The microwave leakage is measured under the conditions specified in Clause 32 and shall not exceed 100 W/m².

22 Construction

This clause of Part 1 is applicable except as follows.

22.101 Built-in appliances shall only be vented through the front, unless provisions are made for venting through a duct.

Compliance is checked by inspection.

22.102 Oven vents shall be constructed so that any moisture or grease discharged through them cannot affect **creepage distances** and **clearances** between **live parts** and other parts of the appliance.

Compliance is checked by inspection.

22.103 The appliances shall be constructed in compliance with either 22.103.1 or 22.103.2.

22.103.1 Appliances shall incorporate at least two **door interlocks** that are operated by opening the door, one being a **monitored door interlock**. At least one of the **door interlocks** shall be concealed and not operable by manipulation.

Compliance is checked by inspection and concealment is checked by 22.105.

NOTE The two **door interlocks** may be incorporated in the system of the **monitored door interlock**.

22.103.2 Appliances shall incorporate two independent **monitored door interlocks** that are operated by opening the door. In this case, 22.105 is not applicable.

NOTE None of the **door interlocks** have to be concealed because there are two independent **monitored door interlocks** incorporating supervision devices.

Compliance is checked by inspection and the following test.

*The door is slowly opened and, simultaneously, an attempt is made to manually defeat any **accessible door interlock** by test probe B one at a time.*

During the tests, the operation of the magnetron shall not be possible.

22.104 At least one **door interlock** of 22.103.1 and both **monitored door interlocks** of 22.103.2 shall incorporate a switch that disconnects the microwave generator or its supply main circuit.

Compliance is checked by inspection.

22.105 At least one of the **door interlocks** shall be concealed and not operable by manipulation. This **door interlock** shall operate before any accessible **door interlock** can be defeated.

Compliance is checked by the following test.

The door is placed in the open or closed position and an attempt is made to operate the concealed **door interlock** by applying test probe B of IEC 61032 to all openings. The test is repeated with a rod, as shown in Figure 101, to any openings of the **door interlock** mechanism. Only one rod shall be used at a time.

Door interlocks that operate magnetically are also evaluated by applying a magnet to the enclosure over the **door interlock** switch. The magnet has a similar configuration and magnetic orientation to the magnets that operate the **door interlock**. It shall be capable of exerting a force of $50\text{ N} \pm 5\text{ N}$ when applied to a mild steel armature having dimensions of $80\text{ mm} \times 50\text{ mm} \times 8\text{ mm}$. In addition, the magnet shall be capable of applying a force of $5\text{ N} \pm 0,5\text{ N}$ at a distance of 10 mm from the armature.

The door is slowly opened and, simultaneously, an attempt is made to manually defeat any **accessible door interlock** with test probe B, the rod and the magnet.

It shall not be possible to operate the concealed **door interlock** during the tests.

22.106 The supervision device of the **monitored door interlock** shall render the appliance inoperable if its switching part fails to control the microwave generator.

Compliance is checked by the following test.

The switching part of the **monitored door interlock** is rendered inoperative. The appliance is supplied at **rated voltage** from a supply source having a short-circuit capacity of at least 1,5 kA for appliances having a **rated voltage** over 150 V and 1,0 kA for other appliances.

NOTE 1 Appliances having a **rated voltage** less than 150 V and a **rated current** over 20 A are supplied at **rated voltage** from a supply source having a short-circuit capacity of at least 5,0 kA.

The appliance is operated with the door closed and an attempt is then made to gain access to the **cavity** in the normal way. It shall not be possible to open the door unless the microwave generator ceases to function and remains inoperable. The supervision device shall not fail in the open-circuit position.

NOTE 2 The supervision device is replaced for subsequent tests if it fails in the closed circuit position.

NOTE 3 It may be necessary to render other **door interlocks** inoperative in order to perform this test.

If an internal fuse in the circuit supplying the microwave generator ruptures, the fuse is replaced and the test is carried out two more times. The internal fuse shall rupture each time.

The test is carried out three more times but with an impedance of $(0,4 + j 0,25)\ \Omega$ in series with the supply source. The internal fuse shall rupture each time.

NOTE 4 For appliances having a **rated voltage** under 150 V and those with a **rated current** over 16 A, the test with the series impedance is not carried out.

NOTE 5 Switches are replaced each time the internal fuse ruptures if this is stated in the instructions for servicing.

22.107 The failure of any single electrical or mechanical component that affects the operation of a **door interlock** shall not cause any other **door interlock**, or the supervision device of the **monitored door interlock**, to become inoperative, unless the appliance is rendered inoperable.

Compliance is checked by inspection and, if necessary, by simulating component failure and operating the appliance as in normal use.

NOTE This requirement does not apply to components of the supervision device that comply with the test of 22.106.

22.108 The **door interlocks** incorporated to comply with 22.103 shall operate before undue microwave leakage occurs.

Compliance is checked by the following test.

All **door interlocks** except one are rendered inoperative. The appliance is supplied at **rated voltage** and operated with the load specified in Clause 32. The door opening sequence is carried out in small increments during which the microwave leakage is measured.

The appliance shall comply with Clause 32.

*The test is repeated on each **door interlock** in turn.*

NOTE 1 **Door interlocks** are only tested if they are necessary for compliance with 22.103.

NOTE 2 It may be necessary to render the supervision device of the **monitored door interlock** inoperative when carrying out the test.

22.109 There shall be no undue microwave leakage if thin material is introduced between the door and its mating surface.

Compliance is checked by closing the door on a strip of paper having a width of 60 mm \pm 5 mm and a thickness of 0,15 mm \pm 0,05 mm, the paper being placed between the door and its mating surface.

The appliance shall then comply with Clause 32.

The test is carried out 10 times with the paper in different locations.

22.110 There shall be no undue microwave leakage if the door seals become contaminated by food residues.

Compliance is checked by the following test.

The door seal is coated with cooking oil. If the seal has an open choke, the trough is filled with oil.

The appliance shall then comply with Clause 32.

22.111 There shall be no undue microwave leakage when the door corners are subjected to distortion.

Compliance is checked by the following test.

*The appliance is supplied at **rated voltage** and operated with the load specified in Clause 32. The door and its opening means are manipulated until the largest door gap permitting microwave generation is obtained. A pull force is applied perpendicular to the surface of the door to each corner in turn. The force is slowly increased to 40 N.*

During the test, the microwave leakage is measured under the conditions specified in Clause 32 and shall not exceed 100 W/m².

After the test, the appliance shall comply with Clause 32.

22.112 There shall be no undue microwave leakage and the **temperature-sensing probe** shall not become damaged, when a probe or its cord is trapped by the door.

Compliance is checked by the following test.

The probe is connected as in normal use, the sensing part or cord being allowed to rest in the most unfavourable position likely to occur. The door is closed against the sensing part of the cord with a force of 90 N applied for 5 s in the most unfavourable place. The force is then released and, if the oven can be operated, the microwave leakage is measured under the conditions specified in Clause 32 and shall not exceed 100 W/m².

*After the test, the appliance shall comply with Clause 32 and the **temperature-sensing probe** shall comply with 8.1, 15.101 and Clause 29.*

22.113 There shall be no undue microwave leakage when **detachable parts** are removed.

Compliance is checked by the following test.

Detachable parts are removed, except **shelves**, unless a horizontal surface greater than 85 mm in diameter is made available when they are removed.

*The appliance shall then comply with Clause 32, the load being placed on the horizontal surface as close as possible to the centre of the **cavity**.*

NOTE In order to avoid detecting non-radiating standing waves, the tip of the instrument probe is not inserted into an opening resulting from the removal of a **detachable part**.

22.114 Appliances shall be constructed so that **shelves** do not fall out of their supports when subjected to a load. **Shelves** intended to be partially withdrawn in use shall not tip when they have partially been removed from the oven.

Compliance is checked by the following test.

*A vessel filled with sand or shot is placed on the **shelf**. The total mass in kilograms is equal to 30 kg/m² of the shelf area. The **shelf**, with the vessel placed centrally on it, is inserted into the oven and moved as close as possible to one of the side walls. It is left in this position for 1 min and then withdrawn. It is then reinserted, moved as close as possible to the other side wall and left for one minute.*

*During the test, the **shelf** shall not fall away from its support.*

*For **shelves** intended to be partially withdrawn in use, the test is repeated with the **shelf** pulled out by 50 % of its depth. An additional force of 10 N is applied vertically downwards on the centre of the exposed front edge of the **shelf**.*

*During the test the **shelf** shall not tip.*

NOTE A small angle of deflection is allowed.

22.115 A single fault such as failure of **basic insulation** or a loose wire bridging the insulation system shall not allow operation of the microwave generator with the door open.

*Compliance is checked by inspection and, if necessary, by simulating relevant faults. Wires that may become loose are disconnected and allowed to fall out of position but are not otherwise manipulated. They shall not come into contact with other **live parts** or earthed parts if this results in all **door interlocks** becoming inoperative.*

NOTE 1 Failure of **reinforced insulation** or **double insulation** is considered to be two faults.

NOTE 2 Wires secured by two independent fixings are not considered likely to become loose.

22.116 There shall be no access to the **cavity** through the viewing screen.

Compliance is checked by inspection and the following test.

*A straight steel rod having a diameter of 1 mm and a flat end is pressed perpendicularly against the viewing screen with a force of 2 N. The rod shall not enter the **cavity**.*

22.117 Interlocks operated by **detachable parts** shall be guarded so that accidental operation is prevented.

Compliance is checked by inspection and by manual test.

22.118 Lights, switches or push-buttons shall only be coloured red if they indicate danger, alarm or similar situations.

Compliance is checked by inspection.

22.119 If **electronic circuits** are used to provide protection against microwave leakage, they shall be designed so that a fault condition will not affect protection against microwave leakage.

Compliance is checked by applying the tests in Clause 19 in conjunction with the requirements and test specifications in 22.105, 22.106, 22.107 and 22.108.

22.120 Appliances for installing in commercial road vehicles, coaches, busses, food stalls and similar vehicles shall withstand the vibrations to which they may be subjected.

Compliance is checked by carrying out the vibration tests specified in IEC 60068-2-6 under the following conditions.

The appliance is fastened in its normal position of use to a vibration-generator by means of straps around the enclosure. The type of vibration is sinusoidal, and the severity is as follows:

- the direction of vibration is vertical;*
- the amplitude of vibration is 0,35 mm;*
- the sweep frequency range is 10 Hz to 55 Hz;*
- the duration of the test is 30 min.*

The appliance shall show no damage that could impair compliance with 8.1, 16.3 and Clauses 29 and 32, and connections shall not have worked loose.

23 Internal wiring

This clause of Part 1 is applicable.

24 Components

This clause of Part 1 is applicable except as follows.

24.1 *Addition:*

NOTE 101 IEC 60989 is not applicable to power transformers that supply the magnetron.

24.1.4 Addition:

*The number of cycles of operation for **thermostats** is increased to 30 000.*

Interlocks are subjected to the following test which is carried out on six samples.

*The interlocks are connected to a load that simulates the conditions occurring in the appliance when it is supplied at **rated voltage**. They are operated at a rate of approximately six cycles per minute. The number of cycles is*

- **door interlocks:** 50 000;
- *interlocks only operated during **user maintenance**:* 5 000.

After the test, the interlocks shall not be damaged to such an extent that their further use is impaired.

24.101 Socket-outlets incorporated in appliances shall be single-phase, incorporate an earthing contact and have a rated current not exceeding 16 A. Both poles shall be protected by fuses or miniature circuit-breakers placed behind a non-detachable cover and having a **rated current** not exceeding

- 20 A, for appliances having a **rated voltage** up to 130 V;
- 10 A, for other appliances.

If the appliance is intended to be permanently connected to fixed wiring, or is fitted with a polarized plug, the neutral pole need not be protected.

Compliance is checked by inspection.

NOTE The actuating member of miniature circuit breakers may be accessible.

25 Supply connection and external flexible cords

This clause of Part 1 is applicable except as follows.

25.1 Modification:

Appliances shall not be provided with an appliance inlet.

25.3 Addition:

Fixed appliances and appliances with a mass greater than 40 kg and not provided with rollers, castors or similar means shall be constructed so that the **supply cord** can be connected after the appliance has been installed in accordance with the installation instructions.

Terminals for the permanent connection of cables to fixed wiring may also be suitable for a **supply cord** of **type X attachment**. In this case, a cord anchorage complying with 25.16 shall be fitted to the appliance.

25.7 Modification:

Instead of the types of **supply cords** specified, the following applies:

Supply cords shall be oil-resistant and shall not be lighter than ordinary polychloroprene sheathed flexible cord (code designation 60245 IEC 57) or equivalent synthetic elastomer sheathed cord.

25.14 Addition:

*For **temperature-sensing probes**, the total number of flexings is 5 000. Probes with circular-section cords are turned through 90° after 2 500 flexings.*

26 Terminals for external conductors

This clause of Part 1 is applicable.

27 Provision for earthing

This clause of Part 1 is applicable except as follows.

27.2 Addition:

Stationary appliances shall be provided with a terminal for the connection of an external equipotential bonding conductor. This terminal shall be in effective electrical contact with all fixed exposed metal parts and shall allow the connection of a conductor having a nominal cross-sectional area up to 10 mm². It shall be located in a position convenient for the connection of the conductor after installation of the appliance.

NOTE 101 Small fixed exposed metal parts, for example nameplates, are not required to be in electrical contact with the terminal.

28 Screws and connections

This clause of Part 1 is applicable.

29 Clearances, creepage distances and solid insulation

This clause of Part 1 is applicable.

30 Resistance to heat and fire

This clause of Part 1 is applicable except as follows.

30.2 Addition:

For appliances that allow a preselected start time and those with a keep-warm function, 30.2.3 is applicable. For other appliances, 30.2.2 is applicable.

31 Resistance to rusting

This clause of Part 1 is applicable.

32 Radiation, toxicity and similar hazards

This clause of Part 1 is applicable except as follows.

Addition:

Compliance for microwave leakage is checked by the following test.

*A load of $275\text{ g} \pm 15\text{ g}$ of potable water having a temperature of $20\text{ °C} \pm 2\text{ °C}$, in a thin-wall borosilicate glass vessel having an inside diameter of approximately 85 mm, is placed on the centre of the **shelf**. The appliance is supplied at **rated voltage** and operated with the microwave power control at the highest setting.*

Microwave leakage is determined by measuring the microwave flux density using an instrument that reaches 90 % of its steady reading in 2 s to 3 s when subjected to a stepped input signal. The instrument antenna is moved over the external surface of the appliance to locate the highest microwave leakage, particular attention being given to the door and its seals.

The microwave leakage at any point 50 mm or more from the external surface of the appliance shall not exceed 50 W/m^2 .

NOTE 101 If compliance with the test is in doubt due to a high water temperature, the test is repeated with a fresh load.

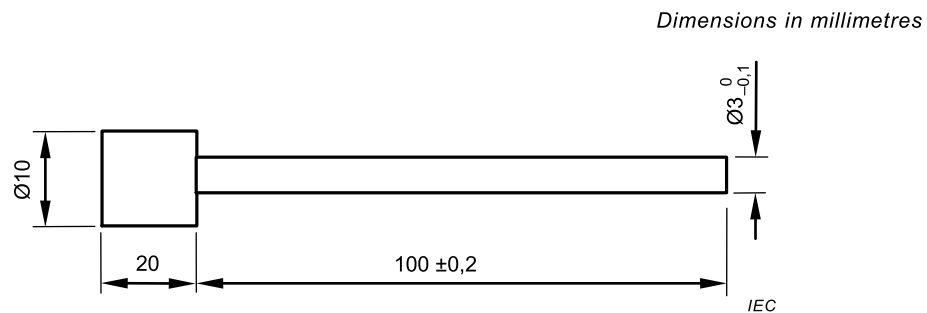

Figure 101 – Test rod for interlock concealment

Annexes

The annexes of Part 1 are applicable except as follows.

Annex A (informative)

Routine tests

This annex of Part 1 is applicable except as follows.

A.2 Electric strength test

Modification:

The current in the test circuit may be increased up to 100 mA.

A.101 Marking and instructions

The covers dealt with in Subclause 7.1 are checked to ensure that they are marked with the warnings concerning microwave energy.

The presence of warning sign and warning text dealt with in Subclause BB.22.119.6 is checked.

The appliance is checked to ensure that the corresponding labels, instructions and manuals are provided with it.

A.102 Construction

*The operation of the **door interlock** system is checked to ensure that microwave generation ceases when the door is opened.*

A.103 Microwave leakage

*The **microwave oven** is supplied at **rated voltage** and operated with the microwave power control adjusted to the highest setting. The energy flux density of microwave leakage is measured at any point approximately 50 mm from the*

- *external surface of the appliance for **microwave ovens** not covered by Annex BB, or*
- ***reference surface** for **microwave ovens** covered by Annex BB.*

*For **microwave ovens***

- *not covered by Annex BB, an appropriate **load** may be used, or*
- *covered by Annex BB, a **load** as specified in BB.3.1.9 shall be used.*

The measuring instrument is moved

- *over the external surface of the appliance for **microwave ovens** not covered by Annex BB, or*
- *over the external surface of the appliance and any **microwave barrier** for **microwave ovens** covered by Annex BB*

and the microwave leakage is measured.

The microwave leakage shall not exceed

- *50 W/m² for **microwave ovens** not covered by Annex BB, or*
- *50 W/m², averaged over the most onerous 20 s interval and 500 W/m² measured as peak value for **microwave ovens** covered by Annex BB.*

A.104 Microwave leakage instrument minimum specifications

The following specification applies only for routine tests and may also apply for checks of **microwave ovens** after repair or servicing. Instruments for type testing shall fulfil more stringent requirements, which are obtained from National bodies responsible for protection against non-ionising radiation.

A.104.1 *Instruments shall be subjected regular calibration by carrying out the following tests, to ensure their accuracy is maintained. The tests for instrument compliance are made at room temperature. For carrying out the tests, the position of the field sensor shall be known and preferably be marked. In order to allow measurements specified in A.104.2 to A.104.4, the minimum resolution of the instrument under test shall be 1 W/m².*

A.104.2 *The level calibrations are carried out either using a generator set-up in an anechoic chamber, or using a reference instrument in substitution mode. The far field shall be linearly polarized. The field sensor of the instrument under test (IUT) shall be placed at the position where the flux density is 10 W/m² or 50 W/m², depending on the task. The range selector, if any, shall be set to the most appropriate range to measure a flux density of 10 W/m² or 50 W/m², depending on the task and with a tolerance from –40 % to +60 %. The overall inaccuracy of the IUT shall be less than or equal to ±1 dB (i.e. from –21 % to +26 %) related to the average of minimum and maximum reading. The field sensor is positioned to the minimum reading and then rotated 4 times for 90° around its axis which is aligned to the propagation direction of the far field and directed towards the radiation source.*

A.104.3 *During the rotation in A.104.2, the maximum deviation of the IUT readings shall be less than or equal to ±2 dB (i.e. from –37 % to +58 %) related to the average of readings.*

A.104.4 *The IUT field sensor is rotated for maximum reading as described in A.104.2 and then held in this position. The field sensor of an equal IUT is rotated as described in A.104.2 and slowly brought in close proximity of the field sensor of the static IUT. During the approach to 50 mm distance between the field sensors, the reading of the static IUT shall not change by more than ±1 dB (i.e. from –21 % to +26 %). During the test, the axis of each field sensor has to be aligned to the propagation direction of the far field and each field sensor has to be directed towards the radiation source.*

Annex AA (normative)

Combination microwave ovens

The following modifications to this standard are applicable for **combination microwave ovens**.

NOTE If a **combination microwave oven** has a mode of operation independent of microwave generation, then this mode has to be tested only according to the requirements in the relevant standard (see Clause 2 of this standard). If a **combination microwave oven** has a mode of operation without the use of resistive heating elements, it is tested to comply with the relevant requirements of this standard.

AA.3 Definitions

AA.3.1.9 Addition:

The appliance is operated with the controls adjusted to the most unfavourable setting in accordance with the instructions for the intended mode of operations.

AA.5 General conditions for the tests

Addition:

NOTE 101 When testing the different modes of operation, only those tests having the most unfavourable conditions are carried out.

AA.5.101 Replacement:

Combination microwave ovens are tested as combined appliances.

AA.11 Heating

Addition:

AA.11.7.101 Combination microwave ovens incorporating resistive heating elements where simultaneous operation is intended, are operated with the resistive heating elements switched on as specified in the manufacturer's instructions under the conditions of Clause 11 of the relevant standard but using the **load specified in 3.1.9, the microwave power output being approximately 50 %.**

If no instructions are provided, the appliance is operated until steady conditions are established.

AA.18 Endurance

Addition:

Before measuring the microwave leakage, the following additional conditioning is carried out.

- *resistive heating elements for radiant heating are operated for 30 min;*
- *resistive heating elements for convection heating are operated for 60 min.*

AA.19 Abnormal operation

AA.19.1 *Addition:*

*The test of 19.102 is carried out at 1,06 times **rated voltage**.*

AA.29 Clearances, creepage distances and solid insulation

Replacement:

This clause of Part 1 is applicable except as follows.

AA.29.2 *Replacement of 2nd paragraph:*

The micro-environment is pollution degree 3 unless the insulation is enclosed or located so that it is unlikely to be exposed to pollution during normal use of the appliance.

AA.29.3 *Addition:*

There are no thickness requirements for sheaths of **visibly glowing heating elements** if the **door interlocks** provide **all-pole disconnection**.

Annex BB (normative)

Requirements for commercial microwave ovens without a cavity door and with conveyor-type means

Annex BB modifies the corresponding clauses and subclauses of Part 2-90 or, where this is not applicable, of Part 1 of IEC 60335, to indicate requirements for commercial microwave ovens without a cavity door and with conveyor-type means. Where it is unclear whether a clause or subclause of this annex is intended to modify the corresponding text of Part 2-90 or that of Part 1, this is specified.

BB.3 Definitions

NOTE For more details, see Figure BB.3.

BB.3.1.9 Replacement:

normal operation

the microwave oven without a cavity door and with **conveyor-type means** is operated according to the manufacturer's instructions. If no instructions are provided, the appliance is operated under the following conditions.

- a) Tunnel type appliances are operated under the following conditions:
 - 1) if the entrance and exit port heights are adjustable, the largest height is used;
 - 2) the highest generator power settings are used.
- b) The load to be heated up consists of N cylindrical containers of borosilicate glass with a maximum thickness of 3 mm and an external diameter of approximately 190 mm, filled with $(1\,000\text{ g} \pm 50\text{ g})$ potable water having an initial temperature of $(20 \pm 2)^\circ\text{C}$. These containers are placed so that all containers are inside the **cavity** and as many as possible microwave generators are operating at the same time.

The number N results from the following formula:

$$N = P/100\text{ W} \quad (P = \text{rated microwave power output [W]}).$$

The result of N shall be rounded off to the nearest integer.

If it is not possible to use these containers, containers of the same material and thickness and with a water mass of not less than $275\text{ g} \pm 15\text{ g}$ shall be used.

An excess number of containers are prepared, so that the whole length and width of the **transportation means** inside the **microwave enclosure** is loaded.

The conveyor speed is set to the lowest reasonable value that will not bring the loads to boiling.

Loads are taken out and are replaced with new cold loads on the **loading area** as they come out on the **removing area**.

- c) Single special load vending type appliances are operated with their intended load. Other vending type appliances are operated under the following conditions.
 - i) Sealed plastic bags with potable water are used, with a water mass corresponding to the weight of typical **loads** for which the appliance is intended.

The appliance is operated for consecutive cycles, the duration of each cycle is determined by the following formula:

$$t = m * 4,187 * \Delta T/P$$

where t is the duration of each cycle [s], m is the mass of the water [g], ΔT is the required temperature rise of 55 K and P is the **rated microwave power output** [W]. The initial temperature should be $20\text{ °C} \pm 5\text{ °C}$.

- ii) New loads are supplied with the shortest possible pauses between runs.

Note 101 to entry: Care should be taken when handling the load.

BB.3.103 *Replacement:*

cavity

space within the **microwave enclosure** where the **load** is heated with high microwave energy

Note 1 to entry: Waveguides between the microwave generator and **cavity** are included since they also contain high microwave energy.

BB.7 **Marking and instructions**

BB.7.1 *Addition to the list of items in Part 1:*

- water pressure or pressure areas in kilopascal (kPa) for the appliances that are determined for the connection to the water supply, or this is fixed in the instructions for use;

Modification of the 5th dash item of Part 1:

- model or type reference and serial number of the appliance. If the generator(s) is separate from the cavity part of the appliance, this information shall also appear on the generator(s);

BB.7.12 *Addition:*

- **WARNING:** Do not programme excessive heating times. Overheating can result in contamination or fire;
- details for necessary cleaning required for hygienic reasons (e.g. **cavity**, **transportation means**) and also for functional reasons (e.g. **means of microwave interlock**, sensor);
- information necessary for dispatch, positioning, installation and operation, including details of weight, dimensions and required minimum distances;

Modification to the 9th indent:

- if smoke is observed, follow the instructions supplied by the manufacturer in order to contain the fire;

Addition:

BB.7.101.1

A label shall be provided, together with instructions for fixing it in a conspicuous place close to the exit port. The label shall state the substance of the following, if applicable.

- **WARNING:** Microwave heating of beverages and similar can result in delayed eruptive boiling, therefore care must be taken when handling the container.
- **WARNING:** Microwaved food and beverages can be very hot, handle with care.

Compliance is checked by inspection.

BB.7.101.2 The instructions for the operator shall include the substance of the following warnings.

- **WARNING:** If parts of **entrance ports and exit ports**, means of access, **viewing openings, microwave barriers**, covers, the **microwave enclosure** or any other means named by the manufacturer are damaged, the appliance shall not be operated until it is repaired by a **skilled person**. Until repairs are carried out, the appliance shall be set in a permanent non-operational condition (e.g. with key switch, code-card or similar devices). Further details shall be included in the instructions for use.
- **WARNING:** Only **Instructed persons** shall operate the **microwave oven**. The **instructed persons** shall regularly, but at a minimum of once a year, be instructed by a **skilled person**. A record of the instruction provided shall be recorded.

BB.7.101.3 The service or repair manual shall include the substance of the following:

- **WARNING:** The **microwave oven** shall comply with requirements of Clause 32 after every repair and according to the instructions of the manufacturer.

Attention: Persons shall not be exposed to excessive emitted microwave energy from the microwave generator. All connections, waveguides, flanges, seals etc. of the **microwave enclosure** and **microwave barriers** shall be safely constructed so that the microwave leakage does not exceed the allowed limit. The operation of the appliance without a microwave absorbing load is to be avoided. The appliance shall be regularly maintained and kept in a good condition to ensure that microwave leakage does not exceed the allowed limit.

The **microwave oven** shall only be maintained by **skilled persons**.

The manufacturer shall supply detailed recommendations on the prevention of cavity fires together with guidance on how fires should be handled, should they occur. Guidance should also be provided on dealing with low water content foods, metal objects and containers with metal.

BB.8 Protection against accessibility to live parts

BB.8.1.1 Addition:

Test probe B of IEC 61032 is applied into openings of less than 75 mm that the probe will permit, to any depth and to a distance of 5 times the minor dimension of openings that are greater than 75 mm, up to a maximum of 850 mm. The probe is rotated or angled to all possible positions, during and after insertion.

BB.9 Starting of motor-operated appliances

BB.9.1 Motors that drive the **transportation means** shall start under all voltage conditions that may occur in use.

*Compliance is checked by starting the motor three times at a voltage equal to 0,85 times **rated voltage**, the motor being at room temperature at the beginning of the test.*

*The motor is started each time under the conditions occurring at the beginning of **normal operation** or, for automatic appliances, at the beginning of the normal cycle of operation. The motor shall be allowed to stop between successive starts. For appliances provided with motors having other than centrifugal starting switches, the test is repeated at a voltage equal to 1,06 times **rated voltage**.*

*In all cases, the motor shall start and it shall function in such a way that safety is not affected and overload **protection devices** of the motor shall not operate.*

NOTE Prior to commencing the test, appliances with **conveyor means** shall be loaded with the heaviest load as specified by the manufacturer. If no instructions are provided, the conditions of BB.3.1.9 apply.

BB.11 Heating

BB.11.7 Modification:

The **microwave oven** is operated as specified in BB.3.1.9 until steady conditions are established.

BB.13 Leakage current and electric strength at operating temperature

BB.13.2 Modification of Part 1:

The last sentence of the fourth paragraph is void.

NOTE An electronic power converter with a supply of more than one phase can be damaged in most cases.

BB.15 Moisture resistance

BB.15.1.1 Addition to Part 1:

Microwave ovens classified as IPX0, IPX1, IPX2, IPX3 and IPX4, which are intended for placing on the floor, shall be subjected for a period of 5 min to the following splash test.

*The apparatus shown in Figure BB.1 is used for the test. During the test, the water pressure is regulated so that the water splashes up 150 mm above the bottom of the bowl. The bowl is placed on the floor for **microwave ovens** normally used on the floor. The bowl is moved around in such a way as to splash the **microwave oven** from all directions. Care shall be taken to ensure that the **microwave oven** is not hit directly by the jet.*

BB.15.2 Addition:

*A quantity of 0,5 l of water containing approximately 1 % NaCl is poured steadily over the most unfavourable parts but excluding the **microwave enclosure**, over a period of 15 s.*

The quantity of 0,5 l of water containing approximately 1 % NaCl, for each kW **rated microwave power output**, is poured steadily at a rate of 0,5 l per 15 s into the **microwave enclosure**.

BB.15.102 Microwave ovens that are provided with a tap intended for filling or cleaning shall be constructed so that the water from the tap cannot come into contact with live parts.

Compliance is checked by the following test.

*The tap is fully opened for 1 min with the **microwave oven** connected to a water supply having the maximum water pressure specified by the manufacturer. Movable parts are placed in the least favourable position. Swivelling outlets on water taps are positioned so that water is directed on to those parts that will give the least favourable test result. Immediately following this treatment, the **microwave oven** shall withstand an electric strength test specified in 16.3.*

BB.18 Endurance

Addition:

The means of access and covers shall be opened and then closed as in normal use. The number of operations is 6 cycles per 1 min or the maximum quantity that is given for the construction.

The following means of access are subjected to the following cycles of operation:

Means of access and **cleaning covers** that can be opened by **instructed persons** for the purpose of venting, flushing lamp covers, cleaning etc. 10 000 cycles

Maintenance covers that can be opened by **skilled persons** 300 cycles

Protective blocking structures which protect **ordinary persons** 200 000 cycles

After the test, the microwave leakage shall not exceed the limit specified in Clause 32 and the system shall still function.

NOTE It may be necessary to render some supervision and system control devices inoperable when carrying out this test.

BB.19 Abnormal operation

BB.19.8 *Addition to Part 1:*

Microwave ovens intended to be star-connected are operated with the neutral conductor being disconnected. Subclause 19.13 shall be applied after the test.

BB.19.13 *Modification:*

The microwave leakage shall not exceed 50 W/m².

BB.19.104 *Addition:*

The most onerous condition, i.e. stopping the belt, shall be selected. During the test, any fire in the **cavity** shall be contained within the appliance.

Table 101 *Replacement of the note with the following:*

NOTE The **rated microwave power output** or the volume of the **cavity** applies, whichever results in the higher number of potatoes. The number of potatoes is increased if the oven does not start.

Addition:

BB.19.105

Appliances are operated with the same load items as in **normal operation** but with load on the **transportation means** only in the **cavity**. The number of load items is the lowest allowing operation of at least one microwave generator at maximum power. The period of operation is the longest allowed by the belt speed setting or similar.

BB.20 Stability and mechanical hazards

BB.20.1 Addition:

Maintenance covers on vending appliances that can be opened and accessories shall be placed in the most unfavourable position.

BB.20.2 Addition after the first paragraph of Part 1:

This is also to be applied on operating elements i.e. handles or hand wheels.

Addition:

*If fans of the **microwave oven** can be operated when the means of access is open, rotating and moving parts of motors and fans shall be located or protected in such a way as to provide adequate protection against injury, when the **microwave oven** is used or when cleaned as intended. It shall not be possible to touch the moving or rotating parts of the fans. To fulfil this requirement it shall be possible to set the **microwave oven** in a permanent non-operational condition (e.g. with key switch, code-card or similar devices).*

Compliance is checked according to the requirements in BB.8.1.1.

BB.20.101 Addition:

Transportation means shall withstand weights according to the instructions of the manufacturer.

Where no instructions are provided, compliance is checked by the following test.

*For appliances with a conveyor belt including **loading areas** and/or **removing areas**, the **transportation means** is stopped and a weight of 23 kg is placed on the **loading area** and **removing area**, in turn. The appliance shall not tilt and there shall be no damage to the **loading area** and **removing area**.*

*For vending-type appliances, the same test is made on the **removing area**, if possible. However, a weight of 8 kg is used.*

NOTE A sandbag may be used for the load. The dimensions of the weight shall accord to the dimensions of the **entrance and exit ports** and to the working area of the **transportation means**.

Addition:

BB.20.102

Protective enclosures according to BB.20.2 shall not be detachable except where

- an appropriate interlock prevents operation of motors or fans without protective enclosures;*
- protective enclosures are a solid part of the housing of the appliance.*

Compliance is checked by inspection.

BB.22 Construction

Subclauses 22.103 to 22.115 are applicable only for cavity doors that are opened by the user for access to the **load**. Such doors are not means of access.

NOTE These types of doors may be found in vending machines.

BB.22.116 Replacement:

This subclause is not applicable.

The following additional subclauses are applicable for these appliances.

BB.22.119 Protection against accessibility to microwave-containing regions

BB.22.119.1 General

Subclause BB.22.119 deals with **entrance and exit ports**, means of access and **viewing openings**. Only **instructed persons** may be close to these ports, means and openings, except that **ordinary persons** may be in the vicinity of **entrance and exit ports** under certain conditions. The particular requirements relating to **ordinary persons** are given in BB.22.119.4.

NOTE 1 In some countries, **instructed persons** are not allowed to have access to the **loading area**. In this case for **ordinary persons** the requirements of this standard may be applied for **instructed persons**.

The microwave leakage and leakage extraction method in Clause BB.32 shall be used for the determination of a **reference surface**. This, together with the type of ports, means and openings and their dimensions determine the specification for **microwave barriers** of the appliance and any separate barrier installations.

NOTE 2 The **microwave barrier** requirements are given in BB.22.119.2 and Table BB.101.

NOTE 3 Requirements on warning signs are also contained in BB.22.119.3.

BB.22.119.2 Microwave enclosure opening and microwave barrier specifications

The dimensions of **viewing openings** and fixed means of access for ventilation, liquid evacuation or similar shall be less than 20 mm × 50 mm.

*A **microwave barrier** shall withstand the tests in Clauses 21.102 and 21.104. Furthermore, it should not be possible to insert test probe B of IEC 61032 through any holes in the barrier, with exception of the accessible end opening.*

Compliance is checked by inspection.

BB.22.119.3 Additionally, the **microwave barrier** shall not be constructed of metal or microwave absorbing material in such a way that it can guide or absorb microwaves, and their accessible openings shall not be larger than the openings which they protect.

The **microwave barrier** shall be removable only with the aid of a tool.

NOTE The function of the **microwave barrier** is to act solely as a mechanical barrier.

Compliance is checked by inspection.

The dimensional and microwave leakage measurement requirements on **microwave barriers** in relation to the dimension and type of opening are given in Table BB.101. The length of the barrier is calculated from the **reference surface**, obtained by the measurements in Clause BB.32. The barrier shall extend all the way to the opening of the **microwave enclosure**.

Table BB.101 – Specifications for microwave barriers

Opening dimension	Allowed use	Required barrier extent	Microwave leakage measurement	Remarks
Allows Ø75 mm	Only entrance and exit ports	See remark	With and without 100 mm rod. 20 s time of integration.	The required barrier length is 5 × the opening minor dimension, up to 850 mm
Ø75 mm to 20 mm × 50 mm	Only entrance and exit ports	180 mm from reference surface	With and without 100 mm rod. 20 s time of integration.	
20 mm × 50 mm to Ø12 mm	Any purpose	80 mm from reference surface	With and without 100 mm rod in entrance and exit ports and viewing openings . 20 s time of integration.	The 100 mm rod is not inserted into permanently open means of access
Ø12 mm to Ø3 mm	Any purpose	None	Only without rod. 20 s time of integration.	Ø12 mm holes in cavity walls will need protection against leakage
< Ø3 mm and narrow slots in metal surfaces	Any purpose	None	Only without rod. The leakage measurement integration time is that of the instrument (2 to 3 s) for narrow slots.	See NOTE 3.

Compliance is checked by inspection and the tests in Clause BB.32.

NOTE 1 A method for testing the microwave properties of the **microwave barrier** is by a heating test of a part of it in a laboratory microwave oven, for about 30 s at 800 – 1 000 W power setting. Appropriate material does not become hot and in particular it does not show any hot spots.

NOTE 2 The mechanical strength test in 21.102 also applies to visually transparent protective devices over or inside **viewing openings**.

NOTE 3 At 2 450 MHz, narrow slots in the **cavity** can radiate significant microwave energy if their length approaches a half wavelength. A contacting part of the body can then be subjected to a very local but high power absorption even when there is a small leakage measured 50 mm away. However, the heated volume is only some few mm³ and heat conduction will limit the temperature rise to a safe level. A shorter integration time is therefore not needed. There may be no leakage from slots less than 3 mm wide in TE₁₀ mode, along a wide side longitudinal centreline or in the short side in the plane of a transverse cross section.

BB.22.119.4 For conveyor type appliances, there shall be a barrier installation in all **loading areas** and **removing areas** where **ordinary persons** place or remove the **load**.

- If the **loading areas** or **removing area** for **loads** is 800 mm above floor level, the barrier shall be at least 1 200 mm high.
- If the **loading areas** or **removing area** for **loads** is 1 000 mm above floor level, the barrier shall be at least 1 400 mm high.
- The requirements for other heights shall be in proportion to the above requirements.
- The distance from any part of the **entrance and exit port** to any periphery of the barrier shall be a minimum of 850 mm from the **reference surface** defined and determined in BB.32.
- It shall not be possible to insert test probe B of IEC 61032 through the barriers.

Compliance is checked by inspection.

NOTE 1 There may be additional barrier type devices that are removable with the aid of a tool.

NOTE 2 The mechanical stability requirements on barrier installations are under consideration.

BB.22.119.5 Vending machines with an exit port shall have either a **protective blocking structure** or a **transportation means**.

In appliances with a **protective blocking structure**, the surface of the structure shall be outside the **reference surface** described in Clause 32, when the **load** is being removed.

Appliances without a **protective blocking structure** shall comply with the requirements in 8.1.1 but in relation to the **reference surface**.

BB.22.119.6 A microwave warning sign (IEC 60417-5140 (2003-04)) of a size specified in IEC 60417 shall be placed in areas where the **entrance and exit ports** are visible through the barrier, or near the opening in the **microwave barrier** through which the **load** is transported.

The warning text shall include the substance of the following.

MICROWAVE ENERGY

DO NOT INSERT THE HAND OR FOREIGN OBJECTS



The same warning sign shall be placed at **viewing openings** with holes larger than \varnothing 12 mm and which are not protected by visually transparent protective devices.

BB.27 Provision for earthing

Addition:

BB.27.101 Any external interconnection cable(s) between a separate main power supply (supplies) in a separate enclosure, and the cavity portion in a separate enclosure or installation shall include an additional earthing wire for high voltage circuits. The insulation of the wire shall comply with the requirements for insulation for operating high voltage.

BB.27.102 Any secondary (high voltage) circuit earthing of magnetrons by a separate wire shall be connected to its waveguide in such a way that the wire does not come loose during service or repair.

BB.30 Resistance to heat and fire

BB.30.2 *Addition:*

Microwave ovens intended to be fed automatically shall be tested according to 30.2.3.

BB.32 Radiation, toxicity and similar hazards

BB.32 Replacement:

Compliance for microwave leakage is checked by the following two test series.

*The **load** specified for **normal operation** is used. The appliance is supplied at **rated voltage** and is operated with the microwave power control at the highest setting.*

Microwave leakage is determined by measuring the microwave flux density using an instrument that reaches 90 % of its steady reading in 2 s to 3 s when subjected to a stepped input signal. To simplify the use of the instrument, a non-interfering spacer is mounted on the sensor probe, providing a required minimum distance of 50 mm between the sensor and any part of the appliance.

*The microwave leakage reading with the sensor at any point 50 mm or more from the external surface of the appliance or any **microwave barrier** shall not exceed 50 W/m², averaged over the most onerous 20 s interval. The instrument reading shall not exceed 500 W/m².*

NOTE 1 Microwave leakage may vary with short heating times, power pulsing and progression of **loads**. Depending on the actual time constant of the instrument, readings are then taken every 2 s or 3 s during some cycles of individual **load** item transport periods.

*In a first test series, the spacer tip is moved over and away from the external surface of the appliance to locate the highest microwave leakage, particular attention being given to the openings and the **microwave barriers**. The region inside a geometric opening into the **microwave enclosure** or **microwave barrier** is not regarded as accessible for this first test series with all barriers in place.*

*A second test series is then carried out at the openings with removed **microwave barriers** (for clarification and information, please see Annex CC) and any interlock to any of them being defeated. A metal rod with 2,5 mm diameter and 100 mm length (test probe C of IEC 61032) is used with the instrument sensor spacer for this test, as shown in Figure BB.2. The appliance is operated under **normal operation**.*

*During the operation, the free rod end is moved in any position near or up to maximum 50 mm depth inside the surface of the geometric openings specified in Table BB.101. The position of the sensor is not to be any closer than 50 mm to any part of the external surface of the appliance, and to the surface of the geometric opening of the **microwave enclosure**.*

For small openings less than 75 mm in diameter, two additional sensor spacer tip and rod locations are to be used: as shown in Figure BB.2 but with the spacer tip and its rod end now placed at the opening; and with the rod centre mounted at the sensor spacer tip and a rod end at the opening.

*If the leakage reading is less than 50 W/m², the **reference surface** is at the surface of the geometric opening of the **microwave enclosure** without **microwave barrier**. If the leakage reading exceeds 50 W/m² under these conditions, the locations of the sensor (not spacer tip) further away from the **microwave enclosure** where this value is measured, are recorded. The position of the **reference surface** away from the surface of the appliance is then determined as 50 mm straight inwards from this sensor position and towards the surface of the appliance.*

NOTE 2 If the **microwave barrier** is mounted inside a part of the external cover of the appliance it will have to be removed for the purpose of the second test series.

NOTE 3 The proper length of the wire is different for operating microwave frequencies other than 2 450 MHz.

Dimensions in millimetres

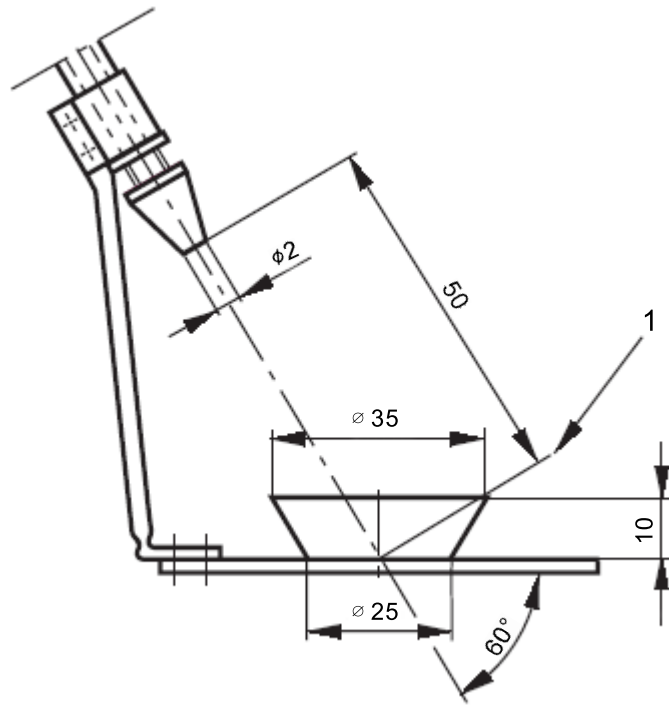

IEC

Key

- 1 bowl

Figure BB.1 – Splash apparatus

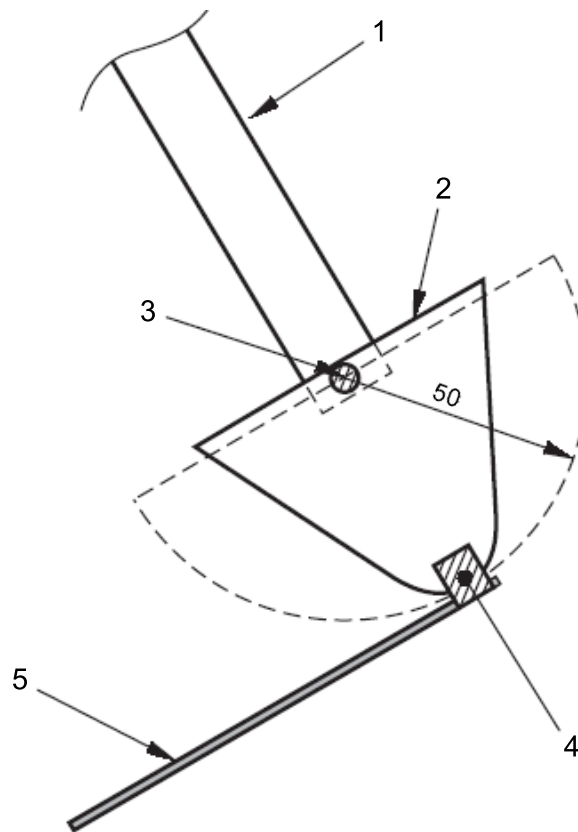
Dimensions in millimetres

IEC

Key

- 1 probe handle
- 2 probe spacer
- 3 field sensor
- 4 tape
- 5 metal rod

A hollow metal tube may be used instead of a solid rod. Its outer dimensions are $l = (100 \pm 1)$ mm, $\varnothing = (2,5 \pm 0,15)$ mm. The metal shall be non-magnetic; aluminium or brass is recommended.

The rod may be fixed to the probe spacer with a thin microwave transparent tape so that the field sensor is located approximately 90° out from the end of the rod. Only when there is not enough space in the vicinity of the access opening is the sensor to be more aligned with the rod. The distance from the rod and any other part of the appliance, including the surface of the access opening to the field sensor, must not be less than 50 mm.

The rod should not be in contact with metal parts, since it is to act as an antenna and spurious readings may then be obtained.

Figure BB.2 – Arrangement for measurement of microwave leakage from access openings

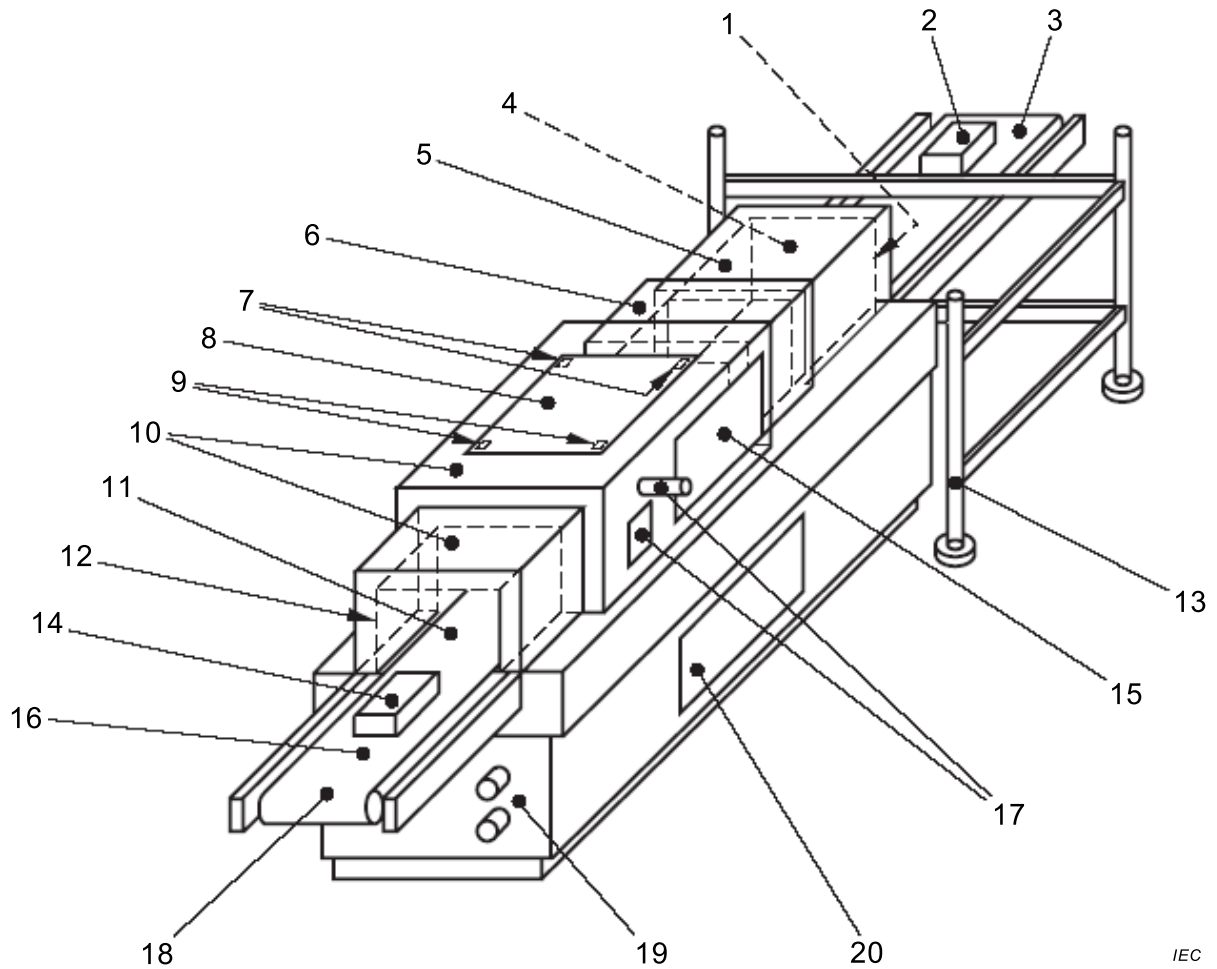

IEC

Key

- | | | | |
|----|--|----|-------------------------------|
| 1 | reference surface | 11 | entrance port |
| 2 | load | 12 | reference surface |
| 3 | removing area | 13 | protective blocking structure |
| 4 | exit port | 14 | load |
| 5 | microwave barrier | 15 | cleaning cover |
| 6 | microwave enclosure | 16 | loading area |
| 7 | means of microwave interlock | 17 | viewing opening |
| 8 | detachable means of access | 18 | transportation means |
| 9 | means of monitored microwave interlock | 19 | fixed means of connection |
| 10 | microwave enclosure | 20 | maintenance cover |

Figure BB.3 – Examples of definitions of Clause 3 and Clause BB.3

Annex CC
(informative)

Overview of the requirements for covers, means of access and similar

Access means	Operated by	Use of tools	Cycles/ Endurance	Interlocks	Monitored interlocks	Warning signs	Instructions	Mechanical	Purpose
Fixed means of access	Instructed persons	No	---	No	No	No	Yes	Steel ball test – Clause 21 with barrier removed	Venting, flushing lamp covers ^a
Means of access that can be opened	Instructed persons	No	10 000	Yes 2 interlocks ^b	Yes 1	No	No	Steel ball test – Clause 21 – with barrier removed	Venting, flushing lamp covers, cleaning
Cleaning cover (see 3.125)	Instructed persons	Yes	10 000	Yes 1 interlock ^c	No	Yes	Yes	Steel ball test – Clause 21 when open	Load correction, inspection, cleaning
Maintenance cover (see 3.124)	Skilled persons	Yes	300	No	No	Yes ^d	Yes	Steel ball test – Clause 21 when open	Lamp covers
Vending machines – Protective blocking structure (see 3.118)	Ordinary persons	No	200 000	No	No	No	No	Steel ball test – Clause 21 when open and closed	To prevent user access to the microwave enclosure ^e

^a Opening of tunnel by drop down or sliding action.

^b It should fulfil requirements in Clause 19.

^c The interlocks shall be located in an area that is free from contamination and the cover shall be self aligned.

^d Appliance has to be shut down, only for service, microwaves behind.

^e These requirements are void if the appliance has cavity door.

Annex DD (informative)

Rationales for the microwave barrier and associated leakage tests

DD.1 The standard measurement of microwave oven leakage

There are several commercial instruments on the market. Those that perform sufficiently well for the purpose have a small, reasonably isotropic (omnidirectional) sensor at the end of a plastic rod. The sensor reacts to the electric field only. There is also a non-disturbing sensor spacer, which is used to determine a 50 mm minimum distance between the sensor and any part of the appliance as specified in the standard. Testing of instruments includes calibration in the far field (the inaccuracy is allowed to be about $\pm 20\%$), and one or two tests intended to show that the sensor is "electrically small" so that it does not itself cause interference (standing waves) to objects nearby.

The scale on microwave leakage instruments is not in the same units as what is actually measured (V/m) but instead in W/m^2 (or mW/cm^2). The conversion is correct only in the free space plane wave case, where the wave impedance is $377\ \Omega$ and there is unidirectional propagation. Since a standing wave is the sum of two waves propagating in different directions, and the probe is not direction sensitive, the field impedance then becomes smaller or larger than $377\ \Omega$, so that the instrument reading becomes erroneous. Erroneous readings are also obtained in strongly curved near fields and with the probe in a waveguide or similar where there is a single or multiple mode (having a different impedance).

The minimum 50 mm distance between the instrument sensor and any accessible part of the appliance was specified more than 35 years ago when the first microwave oven leakage standard was created. The major reasons were that it was found desirable to use the same type of instruments that were used for far-field exposure measurements.

It was concluded that an electric field sensor instrument would not indicate a proper value for determining the outgoing power flux density if the probe was located:

- a) where the field curvature was very significant (in comparison with the wavelength);
- b) in the presence of any standing waves near the sensor.

A reasonable compromise with the need to measure emission (i.e. in the source region, so that the "leaking spot" could be found) was found to be 50 mm for the 2 450 MHz ISM band. Even if it was noted in the instrument literature at the time that the same 50 mm distance would be less appropriate for the lower ISM band at 915 MHz, the matter was not considered so problematic that the specification was modified.

The historical reason for the choice of the maximum allowed level of $50\ W/m^2$ ($=5\ mW/cm^2$) was a result of an existing regulation on free space power flux density of up to $100\ W/m^2$ being acceptable in commercial and industrial environments, plus considerations of a possibility of two or more **microwave ovens** being located close to each other. Later, when household **microwave ovens** came on the market, the nature of door leakage was found to typically be from only some few leaking spots, so that the power flux density decreased almost quadratic with the distance away from these. There was no reason why the user would remain very near the closed door of an operating oven. Widely publicised investigations showed that the actual exposure of any part of the human body became very low, particularly in consideration of a reasonable averaging time of 5 min to 10 min for hazard assessment. As a result, the $50\ W/m^2$ limit was applied also to household **microwave ovens**.

In the beginning of the 1970's, the US authorities responsible for radiation safety found some quality problems with some microwave oven models and introduced a $10\ W/m^2$ "factory limit" for new unused ovens, in order to dampen any public concerns. Only one or two other countries followed.

In the meantime, the SC 61B oven safety standard was successively developed and the value 50 W/m^2 became the worldwide limit after all tests. However, in empty operation and after a potentially destructive door test, 100 W/m^2 was instead required. The rationales for the higher value under no-load conditions were reported difficulties by some manufacturers, and the conclusion that no-load operation would typically be even more short-term and an also uncommon fault condition.

In the 1980's, leakage measurements at covers for lamp replacement were dealt with by IEC SC 61B. The hole array in the cavity wall, at the lamp, can leak microwaves. The size of the cover may be such that the 50 mm distance to the nearest appliance part can be maintained also with the sensor almost inside the external housing from which the cover has been removed. A case had been reported where the instrument reading was quite high in this condition, but there was a very low reading with the whole housing removed. The reason for the high reading was that a standing wave inside the housing had been created. There was an electric field but no real leakage since the standing wave is the sum of an outwards- and inwards-going wave and may have no net power flux. In addition, if a finger would be put into the opening, the standing wave would disappear and only the real leakage becomes the possible hazard. SC 61B added a statement to the standard to the effect that the instrument sensor should not be closer to the opening plane than 50 mm, i.e. the region inside the cover should not be considered accessible with regard to the leakage measurement. The same principle is adhered to in this standard, but the actual leakage situation is now really assessed, by the extended test in Clause 32.

DD.2 Microwave hazards – the basic restriction

Microwave exposure is considered to be potentially hazardous if the heating of parts of the human body exceeds certain values. These are specified as SAR values (specific absorption rate) and are expressed in W/kg tissue. The lowest SAR value of whole-body exposure where there may be some risks has been found to be 4 W/kg . A safety factor of 10 is subsequently applied for microwave workers (**instructed persons**), and a further safety factor of 5 for the general public (**ordinary persons**), resulting in the basic restriction of 0,4 and 0,08 W/kg in the two cases. Local, non-hazardous exposure limited to the head and trunk may be up to 10 W/kg and 2 W/kg , respectively. Twice this (20 W/kg and 4 W/kg) are considered non-hazardous locally in the extremities (including hands and fingers). The integration volumes are then over any 10 g body mass, and the time integration is over 6 min.

DD.3 Microwave hazard evaluation – the free space exposure method

For all practical exposure situations (except from communication devices such as mobile phones for which a total source maximum power concept may apply), two simplified verification methods are used in industry and for protection of microwave workers and the general public, a maximum allowed far-field power flux density far away from the source, and an emission standard for appliances such as **microwave ovens**.

The issue is now if the relaxation of SAR values for parts of the body, in combination with the integration volume, is compatible with the free space exposure method.

When parts of the human body having a small radius of curvature are heated, diffraction, resonant and other focusing or amplification phenomena may occur. In the case of 2 450 MHz, the internal wavelengths in tissues as well as the penetration depth limitation result in only fingers being of major interest. In principle, also bent knuckles and elbows could create focusing effects, but fingers are definitely much more problematic with regard to the effects discussed here. It is not assumed that other protruding parts of the body such as the nose, ears or penis are brought very close to microwave leakage sources in commercial or household heating equipment.

The following modelling results indicate the degree of compatibility between the basic restriction and the free space exposure method:

Numerical modelling using commercially available electromagnetic software was used. A finger with 13 mm diameter and typical dielectric data (homogeneous, with $\epsilon = 40 - j10$, where the loss factor (10) is lowered in consideration of bone and tendons) was exposed to 10 W/m^2 in free space. The strongest absorption occurred for TMz polarisation (i.e. with the impinging electric field parallel to the finger axis) and the mode in the finger then becomes of the TMz₁ type, having two opposite axial zones of maximum heating intensity. The maximum power intensity becomes 5 W/dm^3 and the average over the worst 10 cm^3 becomes about $1,8 \text{ W/dm}^3$.

If the finger would be exposed to a plane wave with a power flux density of 50 W/m^2 , which is allowed from **microwave ovens**, etc., the maximum value would become 25 W/dm^3 and the 10 cm^3 integrated value would become 9 W/dm^3 .

The conclusions are that:

- The ordinary person basic restriction is exceeded. However, **ordinary persons** are with today's standards only exposed to **microwave ovens** with a door, where the leakage source is so small that the high intensity is over a significantly smaller volume of the finger. Additionally, there is no reason to keep the hand near the closed door of an operating microwave oven. There are numerous reports from experimental investigations in the 70's, which clearly indicate the averaged exposure level over several minutes is 10 to 100 times lower than 10 W/m^2 . Therefore, the actual absorption is within the SAR limit.
- The instructed person basic restriction is about the same as the actual SAR value. However, the actual situation with an operator occupied with **load** removal at the port of a continuously operating tunnel microwave oven for long periods is more onerous than with a **microwave oven** with a door, but the working hand can typically not be near the opening more than about half the time. An additional aggravating factor is that the tunnel opening is larger than an oven door as a leakage source, so that the region with a high microwave energy density may extend further out than from an oven door. Therefore, the construction of the tunnel end regions as well as the measurement method must ensure that SAR values in the human finger exceeding those under 50 W/m^2 far field exposure are not exceeded.
- The operating conditions of the tunnel oven shall be such that any higher average leakage levels do not occur. However, parts of a tunnel microwave oven can be operated empty with the operator still removing **loads**. Therefore, the 100 W/m^2 value for an operating empty oven with a door should not be applicable for tunnel ovens.

DD.4 Microwave hazards from openings in cavities, and from tunnel ends

The actually absorbed microwave power in a part of the human body is always very dependent on the field configuration, and the field configuration at the body part is also strongly modified by the part itself. This means that even knowledge about the true power flux density or the electric field intensity cannot be used to assess the actual microwave absorption rate. It becomes necessary to establish a more complete scenario before any calculations of the absorption can be made. Hence, the leakage intensity measured as a quasi-plane free space wave at 50 mm or more away from the source will now not alone determine the level of hazard. The actual hazard also depends on:

- any possibility of access into a region where there is microwave energy;
- the size of the opening, which may determine the type of field characteristics, or allow several kinds of microwave field characteristics;
- any objects, including a **load** to be heated or a part of the body in the opening, which may also determine the type of field characteristics.

The access situation is of course crucial and must be standardised in some ways so that reasonably simple and objective procedures and requirements can be established. Since only the arm, hand and finger are considered to be the parts of the body that may get in contact with or be inserted into openings in these appliances, two important issues can be directly quantified: 1) all geometric factors (by test probe B, etc.), and 2) as addressed above, these parts of the body are less sensitive than for example the head.

An important principle is that a "hazard boundary" (called **reference surface** in this standard) is defined somewhere in the vicinity of the physical opening surface and that a leakage instrument reading of 50 W/m^2 is to apply for the tests. This means that what remains is to construct tests which will ensure, with reasonable certainty, that actual power densities (in W/m^3 , or SAR values in W/kg) in human fingers, hand or arm "contacting" the **reference surface** will not exceed those caused by a "normal" leakage source such as a **microwave oven** door region giving a power flux density reading of 50 W/m^2 at 50 mm distance from any part of the appliance.

The field configuration then becomes the issue, i.e. how to obtain realistic measurement results with the same type of instruments as used for **microwave ovens** with a door. Clearly, there is a need for simplification and standardisation using some typical scenarios. The most important matter is then to consider cases where access would be more severe than in the normal door leakage case. These "onerous" cases are:

- The field configuration is such that there is a very high intensity in a region, and the intensity diminishes very quickly with increasing distance, so that no reading may be obtained but there may still be a quite hazardous microwave energy density 50 mm or less from the instrument sensor. Structures creating non-radiating near fields or strongly evanescent modes have this effect.
- The field configuration is such that a microwave power flux is bound to a dielectric object. A **load** that is heated and is conveyed out of a tunnel oven is the most typical example, and a bound surface wave may then exist, and "transport" a quite large microwave power away from the opening. This may then be manifested as a measurable leakage 500 mm or more away from the opening, whilst no leakage can be measured (using the 50 mm sensor distance) at the opening. A problem with this type of wave is of course that it must be assumed that the operator hand actually contacts the **loads** and then becomes a part of the scenario. Another problem with this kind of wave is that any measured leakage may become spurious and confusing, since it may not be discovered in the region where it emanates.

Cases where a non-hazardous condition exists but a high instrument reading is obtained are also undesirable. The lamp cover case addressed above is of this kind.

In this standard, a method of leakage extraction and non-shielding **microwave barriers** is used. One end of the metal rod may act as a receiving antenna and since the end can be located very close to parts of the oven and **load**, it will also pick up near fields, evanescent modes and surface waves when suitably oriented. A "spatial averaging" of the externally available microwave energy also results, since the instrument sensor is still not closer than 50 mm to any other object.

The tip of the rod may be inserted up to 50 mm into **entrance and exit ports**. This may be considered onerous, but is for discouraging constructions with certain operator-accessible "curtains" intended to reduce leakage, and due to the particular need to compensate for the imperfections of the simple measurement method in view of the wide variety of objects in and geometries of the ports, and possible prolonged operator presence at these ports.

DD.5 The time averaging

There are only two time integration specifications in the existing international standards:

- a) 6 min for whole-body exposure (probably including fingers), and
- b) criteria for duty cycles in cases of very short pulses such as from radar transmitters. Additionally, in some national legislation there is a ceiling value of exposure on non-ionising radiation. A ceiling value of e.g. 250 W/m^2 and a 10 W/m^2 average may be interpreted as maximum $300/25 = 12 \text{ s}$ isolated strong exposure being allowed during any 6 min interval with no exposure during the remaining 5 min 48 s of the interval.

The 6 min integration time is quite compatible with typical cases of irradiation of parts of the body having a radius of curvature larger than about one free space wavelength of 2 450 MHz microwaves. In such cases, essentially a plane damped wave propagation can be assumed, as well as a depth of 30 mm to 40 mm in the tissue over which equilibration by heat conduction takes place. Using the heat conductivity data and the Fourier heat conduction equation then results in a time constant (i.e. about 63 % of the stationary conditions have occurred) of about 5 min. A useful comparison is with boiling of an egg in 100 °C water. It takes about 5 min for the centre to reach a temperature of about 65 °C.

The most onerous heating pattern in a Ø 13 mm finger under plane wave 2 450 MHz irradiation is uneven, with about 5 mm distance between the hot and cold areas. It can be shown that the overall microwave coupling is strongest for about Ø16 mm finger diameter. The corresponding distance between hot and cold areas then becomes 7 mm or less.

The Fourier heat conduction equation is spatially quadratic. Using the boiling of a Ø40 mm egg in 5 min having a distance between the cold and hot regions of 20 mm as a basis, a 7 mm distance would be similarly equilibrated in $(7/20)^2$ of $(5 \cdot 60)$ s, i.e. about 35 s integration time is adequate.

There is however, another factor to also consider. Even a very localised heating rate should not be so high that there will be any risk of pain or injury during the time of integration. A suitable acceptable local temperature rise may be set to 5 K, in consideration of both that the skin area with heat-sensing nerves will be heated at least by conduction and that such a temperature rise under short term conditions will not cause any injury in the fingers. A normal person will feel and react to a temperature increase of the same order or less, about 3 K, within a few seconds.

A homogeneous SAR value of 20 W/kg (the basic restriction for instructed person fingers) will result in a temperature rise rate of about 0,5 K/min.

Now supposing that only e.g. the tip of a finger absorbs all power and the remainder of the 10 g absorbs no power. Such scenarios are actually not uncommon and may occur e.g. with the finger contacting damaged **microwave oven** seals and in some near field cases. The volume of that part of the tip that absorbs microwaves is now set to 0,5 cm³ (which is the volume of a hemisphere with Ø12 mm). Using this in relation to the 10 cm³ of the basic restriction, one obtains a 20 times faster “allowed” temperature rise rate of 10 K/min. This will also mean that the person will feel the heating of the finger within 20 s. Since the equilibration by heat conduction has about the same time constant as above, one again arrives at about 30 s suitable integration time.

There is an extreme case of the tip of the finger touching a leaking narrow slot in a metal surface. The local SAR value becomes very dependent on the dryness of the skin. As an example, a Ø13 mm finger tip with 1 mm dry skin is pressed against the centre of a 2 mm wide and 100 mm long slot. This has a leakage that would be measured to 50 W/m² at 50 mm distance (i.e. the electric field strength is 137 V/m) with no finger. The local SAR value then becomes about 30 W/dm³, over a 4 mm wide and 1,5 mm deep volume. This local value is in itself approximately within the basic restriction. If the finger is wet and the skin is thin, the local SAR value may be up to 50 times larger but the two small heated volumes contacting the slot sides are then only about 1 mm wide and deep. The thermal equilibration distance is now over only 2 mm, so the heat conduction has now a time constant of $(2/20)^2 \cdot (5 \cdot 60)$ s = 3 s. The local, thermally insulated heating rate could be up to 40 K/min. However, heat conduction would result in a stationary temperature rise of less than about 3 K, which is also acceptable. Hence, there is no need to have a shorter integration time than about 30 s even in this most onerous case of high local SAR values in microwave cavity oven situations.

DD.6 Conclusions and modifications of the standards for ovens with a cavity door

The 6 min time of integration specified in existing international standards is inadequate for the purposes now under investigation by SC61B. A more realistic value should be 30 s. There may be cases of open-ended microwave applicators intended for heating of a contacting load. Such applicators may cause almost instantaneous injury if contacted by any part of the body when in operation, and other provisions for safety must be applied.

The existing emission standard for **microwave ovens** specifies an integration time of about 2 s for the measurement. This is for historical and practical rather than safety reasons. A typical household **microwave oven** has either a ceiling stirrer or a turntable, and with the specified circularly cylindrical test load, the leakage variation periodicity will be comparable to or less than the specified integration time. Measurements are then correct and made easily and quickly with the present standard.

Since the door less appliances considered in Annex DD may behave quite differently and there is no reason to introduce limitations on construction that have no relevance to safety considerations, 20 s time of integration for leakage measurements shall be applied. This is shorter than 30 s, but also allows for faster measurements and easier integration. The most onerous 20 s interval shall be chosen and the instrument integration time of 2 s to 3 s shall be maintained.

For reasons given here, the allowed leakage level shall not be 100 W/m^2 in empty operation, as for **microwave ovens** with a door. The regular value of 50 W/m^2 shall apply.

In addition, a maximum measured (integrated, ceiling) value of 500 W/m^2 , consistent with the instrument integration time of 2 s to 3 s, is introduced to simplify instrument specifications and handling as well as the numerical integration in cases of highly variable leakage. Such strong variability may occur for example in appliances with a protective device consisting of a built-in leakage monitor coupled to a cut-out.

Annex EE (normative)

Microwave ovens intended to be used on board ships

Annex EE modifies the corresponding clauses and subclauses of Part 2-90 or, where this is not applicable, of Part 1 of IEC 60335, to indicate requirements for commercial **microwave ovens** intended to be used on board ships. Where it is unclear whether a clause or subclause of this annex is intended to modify the corresponding text of Part 2-90 or that of Part 1, this is specified.

3 Terms and definitions

EE.3.101

open deck

area which is exposed to marine environment

EE.3.102

dayroom

area which may be exposed to marine environment from time to time

EE.6 Classification

EE.6.2 *Addition to Part 1:*

Appliances for **open deck** use shall be IPX6.

EE.7 Marking and instructions

EE.7.1 *Modification:*

Replacement of the second dashed item of Part 1 by the following:

- **rated frequency** or **rated frequency range** in Hz;

EE.7.12 *Addition:*

The instructions for use shall also include the substance of the following.

- usage on board ships;
- installation place (**open deck** protective enclosure, **dayrooms**);
- fastening means.

Modification:

Replacement of the eleventh dashed item by the following:

- details for cleaning door seals, **cavities**, **shelves** and adjacent parts;

EE.11 Heating

Addition to 11.5 of Part 1:

Microwave ovens marked with a **rated frequency** are tested with the most onerous frequency within $\pm 4\%$ of the **rated frequency**.

Microwave ovens marked with a **rated frequency range** are tested with the most onerous frequency within this range.

EE.22 Construction

EE.22.101 Appliances shall withstand the pulses to which they may be subjected.

Compliance is checked by carrying out the half-sine pulse tests specified in IEC 60068-2-27 under the following conditions.

The appliance is fastened in its normal position of use to a shock-testing machine by means of straps around the enclosure.

The type of pulse is a half-sine pulse and the severity is as follows:

- application of the half-sine pulse is in all 3 axes;
- peak acceleration: 250 m/s²;
- duration of each half-sine pulse: 6 ms;
- number of half-sine pulses in each direction: 1 000 \pm 10.

The appliance shall show no damage that could impair compliance with 8.1, 16.3, Clause 29 and Clause 32 and connections shall not have worked loose.

EE.22.102 Appliances shall withstand the vibrations to which they may be subjected.

Compliance is checked by carrying out the vibration tests specified in IEC 60068-2-6 under the following conditions:

The appliance is fastened in its normal position of use upon a vibration table by means of straps around the enclosure. The type of vibration is sinusoidal and the severity is as follows:

- direction of vibration is vertical and horizontal;
- amplitude of vibration: 0,35 mm;
- sweep frequency range: 10 Hz to 150 Hz;
- duration of the test: 30 min.

The appliance shall show no damage that could impair compliance with 8.1, 16.3, Clause 29 and Clause 32 and connections shall not have worked loose.

EE.22.103 Shelves shall have a **non-detachable** slip resistant top surface.

Compliance is checked by inspection and the following test.

*The top surface of the **shelf** is coated with cooking oil. The appliance is placed with the door forwards on and fixed to a surface which can be tilted downwards to the right in one direction by 12°. An empty dinner plate as described as item No. 1 in Clause A.2 of IEC 60436:2004 is used for the test and placed centrally on the **shelf**. The oven is then slowly tilted.*

*In a second test and for **microwave ovens** with rotatable **shelves**, the **shelf** is rotated by 90°, the plate is again placed centrally and the **microwave oven** is then slowly tilted. For **microwave ovens** with **non-detachable shelves**, the **microwave oven** is rotated by 90°, the plate is again placed centrally and the **microwave oven** is then slowly tilted.*

During each of these tests, the plate shall not slide onto a raised shelf periphery if any, or onto the cavity wall.

NOTE During the tests, the oven is not energised and it is possible that the cavity door is open.

EE.31 Resistance to rusting

Addition to this clause of Part 1:

Compliance is checked by the salt mist test Kb of IEC 60068-2-52:

- for **open deck** use, severity 1 is applicable;*
- for **dayrooms** use, severity 2 is applicable.*

Before the test, coatings are scratched by means a hardened steel pin, the end of which has the form of a cone with an angle of 40°. Its tip is rounded with a radius of 0,25 mm ± 0,02 mm. The pin is loaded so that the force exerted along its axis is 10 N ± 0,5 N. The scratches are made by drawing the pin along the surface of the coating at the speed of approximately 20 mm/s. Five scratches are made at least 5 mm apart and at least 5 mm from the edges.

After the test, the appliance shall not have deteriorated to such an extent that compliance with this standard, in particular with Clauses 8 and 27, is impaired. The coating shall not be broken and shall not have detached from the metal surface.

Bibliography

The bibliography of Part 1 is applicable except as follows.

Addition:

IEC 60335-2-25, *Household and similar electrical appliances – Safety – Part 2-25: Particular requirements for microwave ovens, including combination microwave ovens*

IEC 60335-2-36, *Safety of household and similar electrical appliances – Part 2-36: Particular requirements for commercial electric cooking ranges, ovens, hobs and hob elements*

IEC 60335-2-42, *Safety of household and similar electrical appliances – Part 2-42: Particular requirements for commercial electric forced convection ovens, steam cookers and steam-convection ovens*

IEC 60335-2-49, *Household and similar electrical appliances – Safety – Part 2-49: Particular requirements for commercial electric hot cupboards*

IEC 60335-2-75, *Safety of household and similar electrical appliances – Part 2: Particular requirements for commercial dispensing appliances and vending machines*

IEC 60519-6, *Safety in electroheat installations – Part 6: Specifications for safety of industrial microwave heating equipment*

IEC 60601 (all parts), *Medical electrical equipment*

IEC 60989, *Separating transformers, autotransformers, variable transformers and reactors*

IEC 61270-1, *Capacitors for microwave ovens – Part 1: General*

INTERNATIONAL
ELECTROTECHNICAL
COMMISSION

3, rue de Varembé
PO Box 131
CH-1211 Geneva 20
Switzerland

Tel: + 41 22 919 02 11
Fax: + 41 22 919 03 00
info@iec.ch
www.iec.ch